

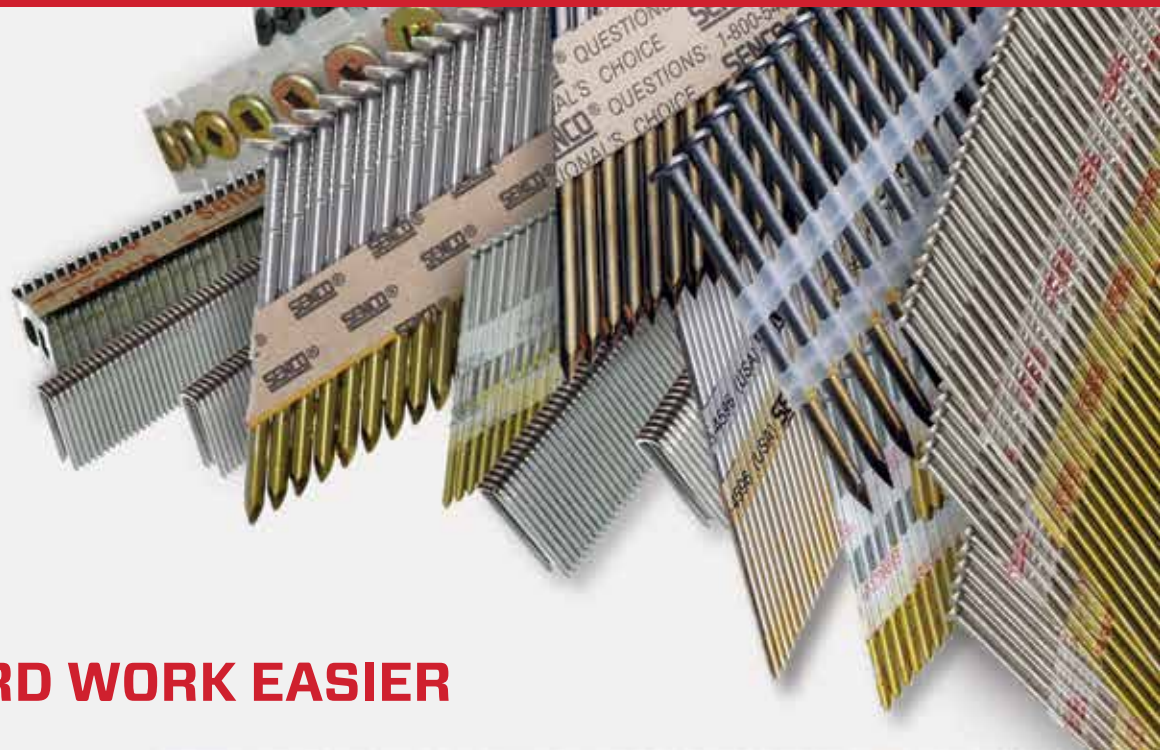

SENCO®

2015 PRODUCT CATALOG



MAKING HARD WORK EASIER



Since 1948, Senco has been synonymous with professional results, quality, increased productivity and craftsmanship.

Customers around the world have put Senco's innovative products to work in a variety of demanding applications, counting on them to perform every day. Today, Senco continues to pioneer new technologies in all areas of professional fastening solutions.

At Senco, our mission is to be the undisputed provider of choice for quality fastening solutions that increase productivity and make work safer and easier to perform. We value input from our users and focus on responsive innovations that make fastening simpler and more efficient.

We promise to be a true partner in creating fastening solutions, focused on the needs of our customers and users by providing expertise and innovations that make hard work easier.

We design and engineer every Senco fastening system to deliver outstanding results and maximize productivity.

We have a focus on safety because we want everyone who uses our products to have a long and injury-free career.

At Senco, we are dedicated to bringing you only the best in professional fastening systems.

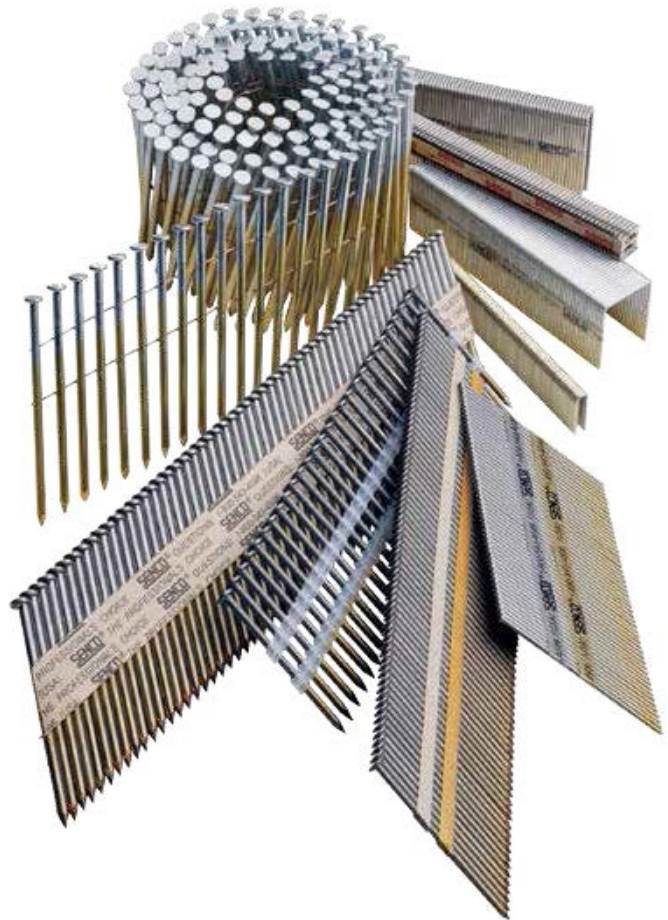



MAKING HARD WORK EASIER

TABLE OF CONTENTS

See all Tools-At-A-Glance fold out located on pages 82 - 84.

Auto-Feed Screwdrivers

DS215-18V, DS212-18V, DS312-18V	3
DS235-AC, DS232-AC, DS332-AC	4
DS425AC, DS440AC	5
DS220, DS320	6
SG4100, SG2510	7
Collated Screws	8 - 11
Screw System Accessories	12 - 13



Fusion

F18, F16-S, F16-A, F-15	15
Fasteners	16 - 17



Finish & Woodworking

FinishPro23SXP, FinishPro23LXP, FinishPro21LXP	19
FinishPro18Mg, SLP20XP, FinishPro25XP, FinishPro32	20
FinishPro33Mg, SFN30, FinishPro35Mg, FinishPro42XP	21
SLS20XP, SLS25XP, SKSXP	22
SLS150Mg, SLS18Mg, SC1XP Senclamp, SC2 Sencor	23
Fasteners	24 - 29



Framing, Sheathing & Subfloors

FramePro325XP, FramePro701XP, SN951XP	31
FramePro325FRHXP, FramePro702XP, FramePro752XP, SN952XP	32
SCN60XP, SCN65XP, SCN63LDXP, SCN49XP	33
JoistPro150XP, JoistPro250XP, Mini-Hand Nailer, A20 Hand Nailer	34
SCP40XP, WC150XP, WC200XP	35
SNS41, SNS200XP, SQS55XP	36
Fasteners	37 - 45



Roofing & Siding

RoofPro455XP, RoofPro445XP, SCN49XP	47
WC150RXP, BC58, A11	48
Fasteners	49 - 51



Pallets & Crating

PalletPro57FXP, PalletPro100XP, PalletPro130XP	53
DFPXP, F75LXP, F75SXP	54
Fasteners	55 - 57



Upholstery & Furniture

SFT10XP Family	59
SFW09, SNS200XP-BST	60
Fasteners	61 - 63



Flooring

SHF200, SHFS200, SLS20XP-HF	65
Fasteners	66



Box, Carton & Pallet Conversion Fasteners

Nails, Staples, Screws	67 - 69
------------------------	---------



Compressors

PC0968N, PC0969, PC0970	71
PC1130, PC1131, PC0968, PC1280	72
PC1010, PC0947, PC1010N, PC0974	73



Accessories

Air Hoses	75
Plugs & Couplers, Swivel Plugs & Couplers	76 - 77
Air Hose & Compressor Accessories	77 - 78
Drain Cock, Filters, Regulators & Gauges	78
Oils & Lubricants	79
Safety Glasses & Tool Belt Hooks	79
Battery & Charger Systems, No-Mar Pads	80
Parts Kit	81



Miscellaneous

Tools-At-A-Glance	82 - 84
Item Code Index	85

DURASPIN

DESIGNED TO MAKE YOU AS PRODUCTIVE AS POSSIBLE

DuraSpin® systems increase screw fastening speeds by more than four times versus bulk screwdrivers and loose screws and improving job site productivity by 30% or more. Now, we're leading the way to even greater productivity gains with our next generation of tools and fasteners.

APPLICATIONS

Whether you choose an integrated tool or use our full line of kits and accessories, you can customize Duraspin auto-feed screw systems for a variety of applications including drywall, flooring, decking and industrial projects. Check out our ICC collated screws for steel frame construction.

FEATURES

- Patented corner fit feed system for better screw placement in tight spaces and corners
- Locking depth-of-drive adjustment
- Tool-free adjustable nose piece
- Easy load 50 screws in less than a second
- Trigger lock: locks in RPM speed
- Long-lasting drive bits with quick-slide release



DS215-18V

2" CORDLESS 18V LI-ION 5000 RPM

ITEM# 7W0001N



2 bits included



Features

- High-speed motor designed for drywall applications
- Patented feed system fits into corners
- EZ Load feature for quick loading
- Includes 2 bits (as shown), drywall nosepiece FC0878, wood nosepiece FB0157, 2 batteries, charger and carrying bag

PRIMARY APPLICATIONS

Drywall to Wood
Drywall to Steel
Underlayment

SECONDARY APPLICATIONS

Cement Board

DS212-18V

2" CORDLESS 18V LI-ION 2500 RPM

ITEM# 7X0001N



2 bits included



Features

- High-torque motor for driving into dense material
- Drives drill-point fasteners with variable speed trigger
- Depth-of-drive lock ensures same countersink every time
- Includes 2 bits (as shown), drywall nosepiece FC0878, wood nosepiece FB0157, 2 batteries, charger and carrying bag

PRIMARY APPLICATIONS

Metal Framing
Cement Board

SECONDARY APPLICATIONS

Drywall to Wood
Drywall to Steel
Subfloo
Underlayment
Wood Decking
Sheathing to Steel

DS312-18V

3" CORDLESS 18V LI-ION 2500 RPM

ITEM# 7Y0001N



2 bits included



Features

- Tool-free screw-length adjustment to set screw length quickly
- Load quickly and prevent misfeeds with patented screw strip guide
- Drive the complete range of SENCO collated screws up to 3"
- Includes 2 bits (as shown), drywall nosepiece FC0895, wood nosepiece FB0159, 2 batteries, charger and carrying bag

PRIMARY APPLICATIONS

Wood Decking

SECONDARY APPLICATIONS

Drywall to Wood
Drywall to Steel
Subfloo
Underlayment
Metal Framing
Composite Decking
Cement Board
Sheathing to Steel

Product Reference Chart

TOOL SPECS	DS215-18V	DS212-18V	DS312-18V
Speed (RPM)	0-5000	0-2500	0-2500
Voltage	18V	18V	18V
Weight	5.3 lbs (2.4 kg)	5.6 lbs (2.43 kg)	6.0 lbs (2.7 kg)
Height	9.5" (241 mm)	9.5" (241 mm)	9.5" (241 mm)
Length	15" (381 mm)	15" (381 mm)	16.4" (415.9 mm)
Width	3.9" (98.4 mm)	3.9" (98.4 mm)	3.9" (98.4 mm)
Warranty	1 yr	1 yr	1 yr
FASTENER SPECS	Collated screws are located on pages 8 - 11.		
Range	1"-2"*	1"-2"*	1"-3"
Shank Diameter	#6-#8	#6-#10	#6-#10
TOOL FEATURES			
Depth-of-Drive	Yes	Yes	Yes
Reversible Belt Hook	Yes	Yes	Yes
Trigger	Variable speed	Variable speed	Variable speed
Power Type	18V 1.5 Ah Compact Li-Ion	18V 1.5 Ah Compact Li-Ion	18V 1.5 Ah Compact Li-Ion
Reversible	Yes	Yes	Yes

All cordless screwdrivers come with (2) 18V Li-Ion batteries (VB0155), charger (VB0156), drywall nosepiece, wood nosepiece, and storage bag.

*FC0822 Nosepiece drives 1/2" to 2" screws

One Common Battery Platform

SENCO's 18V Li-Ion Battery System is designed for long running times with quick recharges and operates at full speed until depleted, so there is no gradual drop in power during use. Special LED fuel gauge displays battery life with a touch of a button.

Senco's 18V Li-Ion batteries work for all Fusion Finish Nailers and all Cordless Duraspin Auto-Feed Screw Systems.

See the complete Senco Battery Platform in the accessories section on pages 13 and 80.



DS235-AC

2" CORDED 5000 RPM

ITEM# 7T0001N



2 bits included



Features

- High-speed motor designed for drywall applications
- Patented feed system fits i to corners
- EZ Load feature for quick loading
- Includes 2 bits (as shown), drywall nosepiece FC0878, wood nosepiece FB0157 and carrying bag

PRIMARY APPLICATIONS

Drywall to Wood
Drywall to Steel
Underlayment
Cement Board

SECONDARY APPLICATIONS

Subfloo
Wood Decking

DS232-AC

2" CORDED 2500 RPM

ITEM# 7U0001N



2 bits included



Features

- High-torque motor for driving into dense material
- Drives drill-point fasteners with variable-speed trigger
- Depth-of-drive lock ensures same countersink every time
- Includes 2 bits (as shown), drywall nosepiece FC0878, wood nosepiece FB0157 and carrying bag

PRIMARY APPLICATIONS

Metal Framing
Cement Board

SECONDARY APPLICATIONS

Drywall to Wood
Drywall to Steel
Subfloo
Underlayment
Wood Decking
Composite Decking

DS332-AC

3" CORDED 18V LI-ION 2500 RPM

ITEM# 7V0001N



2 bits included



Features

- Tool-free screw-length adjustment to set screw length quickly
- Load quickly and prevent misfeeds with patented screw-strip guide
- Drive the complete range of SENCO collated screws up to 3"
- Includes 2 bits (as shown), drywall nosepiece FC0895, wood nosepiece FB0159 and carrying bag

PRIMARY APPLICATIONS

Wood Decking
Composite Decking
Sheathing to Steel

SECONDARY APPLICATIONS

Drywall to Wood
Drywall to Steel
Subfloo
Underlayment
Metal Framing
Cement Board

Product Reference Chart

TOOL SPECS	DS235-AC	DS232-AC	DS332-AC
Speed (RPM)	0-5000	0-2500	0-2500
Current (Amps)	6.0	6.0	6.0
Voltage	120V/60Hz	120V/60Hz	120V/60Hz
Weight	5.7 lbs (2.6 kg)	5.8 lbs (2.6 kg)	5.9 lbs (2.7 kg)
Height	9.5" (241.3 mm)	9.5" (241.3 mm)	9.5" (241.3 mm)
Length	16.4" (415.9 mm)	16.4" (415.9 mm)	17.3" (438.2 mm)
Width	3.4" (85.7 mm)	3.4" (85.7 mm)	3.4" (85.7 mm)
Warranty	1 yr	1 yr	1 yr
FASTENER SPECS	Collated screws are located on pages 8-11.		
Range	1"-2"*	1"-2"*	1"-3"
Shank Diameter	#6-#10	#6-#12	#6-#12
TOOL FEATURES			
Depth-of-Drive	Yes	Yes	Yes
Reversible Belt Hook	Yes	Yes	Yes
Trigger	Variable speed	Variable speed	Variable speed
Power Type	Corded	Corded	Corded
Reversible	Yes	Yes	Yes

All corded screwdrivers come with drywall nosepiece, wood nosepiece, and storage bag. *FC0822 Nosepiece drives 1/2" to 2" screws

DS425AC

3" ATTACHMENT KIT WITH 2500 RPM SCREWDRIVER

ITEM# 6W0012N

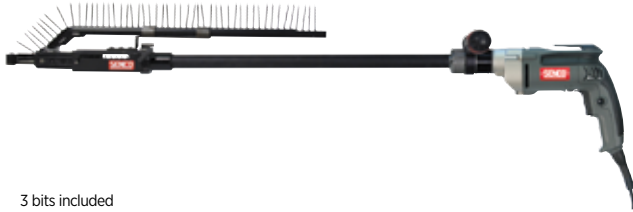

3 bits included



Features

- 3 Tools in 1 providing configurations for multiple applications
- High-torque motor powerful enough for any application
- EZ Load feature for quick loading
- Prevent misfeeds with patented sliding rail system
- Includes SG2510 screwdriver, DS320 attachment, adaptor, 3 bits (as shown) and carrying bag

PRIMARY APPLICATIONS

Metal Framing
Wood Decking
Composite Decking
Cement Board
Sheathing to Steel

SECONDARY APPLICATIONS

Drywall to Wood
Drywall to Steel
Subfloor
Underlayment

DS440AC

3" ATTACHMENT KIT WITH 4000 RPM SCREWDRIVER

ITEM# 6W0011N



3 bits included



Features

- 3 Tools in 1 providing configurations for multiple applications
- High-speed motor designed for subfloor applications
- EZ Load feature for quick loading
- Prevent misfeeds with patented sliding rail system
- Includes SG4100 screwdriver, DS320 attachment, adaptor, 3 bits (as shown) and carrying bag

PRIMARY APPLICATIONS

Subfloor
Underlayment
Wood Decking
Cement Board

SECONDARY APPLICATIONS

Drywall to Wood
Drywall to Steel

Product Reference Chart

TOOL SPECS	DS425AC	DS440AC
Speed (RPM)	0-2500	0-4000
Current (Amps)	6.4	6.4
Weight	7 lbs (3.2 kg)	6.8 lbs (3.1 kg)
Height	7.5" (190 mm)	7.5" (190 mm)
Length	20.5" (521 mm) 40" (1016 mm) w/ext. pole	20.5" (521 mm) 39.5" (1003 mm) w/ext. pole
Width	2.5" (63 mm)	2.5" (63 mm)
Warranty	1 yr	1 yr
FASTENER SPECS	Collated Screws are located on pages 8 - 11.	
Range	1"-3"	1"-3"
Shank Diameter	#6 - #12	#6 - #12
TOOL FEATURES		
Depth-of-Drive	Yes	Yes
Belt Hook	Yes	Yes
Trigger	Variable with lock	Variable with lock
Power Type	Corded	Corded
Reversible	Yes	Yes

3 Tools in 1

Quickly and easily convert your DS425AC or DS440AC auto-feed attachment kit into 3 tools for multiple applications.



1. Use the screwdriver to drive loose screws.

2. Use the attachment for multiple auto-feed applications.



3. Add the extension pole for stand-up applications like subfloor and decking.

DS220

2" AUTO-FEED SCREWDRIVER ATTACHMENT

ITEM# 6W0001N



Features

- Prevent mis-feeds with patented sliding rail system
- Depth-of-drive lock ensures same countersink every time
- Attaches to your existing screwdriver with our full line of adapters (*sold separately)
- Includes 2" attachment, drywall nosepiece FC0878 and wood nosepiece FB0157

PRIMARY APPLICATIONS

Drywall to Wood
 Drywall to Steel
 Metal Framing
 Cement Board
 Sheathing to Steel

SECONDARY APPLICATIONS

Subfloo
 Underlayment
 Wood Decking
 Composite Decking

Bits and adapters sold separately

DS320

3" AUTO-FEED SCREWDRIVER ATTACHMENT

ITEM# 6W0003N



Features

- Prevent mis-feeds with patented sliding rail system
- Perfect for stand-up applications using the extension pole and adjustable handle
- Attaches to your existing screwdriver with our full line of adapters (*sold separately)
- Includes 3" attachment, extension pole, adjustable handle, drywall nosepiece FC0895 and wood nosepiece FB0159

PRIMARY APPLICATIONS

Subfloo
 Underlayment
 Wood Decking
 Composite Decking
 Cement Board
 Sheathing to Steel

SECONDARY APPLICATIONS

Drywall to Wood
 Drywall to Steel
 Metal Framing

Bits and adapters sold separately

Product Reference Chart

TOOL SPECS	DS220	DS320
Weight	1.5 lbs (.68 kg)	3.33 lbs (1.5 kg)
Height	3.5" (89 mm)	3.5" (89 mm)
Length	20.5" (521 mm)	21" (533 mm)
Width	2.5" (63 mm)	2.5" (63 mm)
Warranty	1 yr	1 yr
FASTENER SPECS	Collated screws are located on pages 8-11.	
Range	1"-2"*	1"-3"
Shank Diameter	#6 -#10	#6 -#12
TOOL FEATURES		
Depth-of-Drive	Yes	Yes

Additional screwdrivers, bits and adaptors sold separately — see page 12
 *FC0822 Nosepiece drives 1/2" to 2" screws

Adapters for over 32 screwdriver motors

including DeWALT®, Makita®, HITACHI and SIOUX™.



SG4100

HIGH-PERFORMANCE 4000 RPM SCREWDRIVER

ITEM# 6X0004N



2 bits included



Features

- High-speed motor designed for drywall applications
- Industrial-grade metal gear housing designed to sustain heavy usage
- Great for all-day use with ergonomic, lightweight and compact design
- Trigger lock for continuous operation
- Industrial-grade 10' cord
- Includes 2 bits (as shown)

PRIMARY APPLICATIONS

Drywall to Wood
Drywall to Steel
Subfloor
Underlayment
Cement Board

SECONDARY APPLICATIONS

Wood Decking

SG2510

HIGH-PERFORMANCE 2500 RPM SCREWDRIVER

ITEM# 6X0002N



2 bits included



Features

- High-torque motor for driving into dense materials
- Industrial-grade metal gear housing designed to sustain heavy usage
- Great for all-day use with ergonomic, lightweight and compact design
- Trigger lock for continuous operation
- Industrial-grade 10' cord
- Includes 2 bits (as shown)

PRIMARY APPLICATIONS

Composite Decking
Wood Decking
Cement Board
Sheathing to Steel
Metal Framing

SECONDARY APPLICATIONS

Drywall to Wood
Drywall to Steel
Subfloor
Underlayment

Nosepieces & drive bits for every application,

drywall, wood, wood to metal and metal to metal.







Product Reference Chart

TOOL SPECS		
Speed (RPM)	0 - 4000	0 - 2500
Current (Amps)	6.4	6.4
Weight	3.4 lbs (1.5 kg)	3.6 lbs (1.6 kg)
Height	7.5" (190 mm)	7.5" (190 mm)
Length	12" (305 mm)	12.5" (317 mm)
Width	2.5" (63 mm)	2.5" (63 mm)
Warranty	1 yr	1 yr
TOOL FEATURES	SG4100	SG2510
Depth-of-Drive	Yes	Yes
Belt Hook	Yes	Yes
Trigger	Variable Speed	Variable speed
Power Type	Corded	Corded
Reversible	Yes	Yes

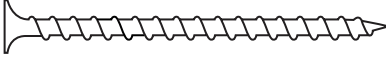
Drywall to Wood Screws





Sharp-point drywall screws for fastening interior drywall to wood

Finish: Gray Phosphate				
				
 #2 Phillips  Bugle  Sharp				
Gauge	Length	Thread	Quantity	Item Code
#6	1¼"	Coarse	1000 Tub	06A125P
#6	1¼"	Coarse	4000 Box	06A125PB
#6	1½"	Coarse	1000 Tub	06A162P
#6	1½"	Coarse	4000 Box	06A162PB
#7	2"	Coarse	1000 Tub	07A200P
#8	2½"	Coarse	1000 Box	08A250PK

Finish: Exterior				
				
Gauge	Length	Thread	Quantity	Item Code
#6	1½"	Coarse	1000 Tub	06A162W





Drywall to Light Steel Screws

Sharp-point, fine-thread drywall screws for interior drywall to light gauge metal studs

Finish: Gray Phosphate				
				
 #2 Phillips  Bugle  Sharp 				
Gauge	Length	Thread	Quantity	Item Code
#6	1¼"	Double Thread	1000 Tub	06B125P*
#6	1¼"	Double Thread	4000 Box	06B125PB*
#6	1½"	Double Thread	1000 Tub	06B162P*

Gypsum to Heavy Steel Screws

Drywall screws with self-drilling point for fastening drywall or gypsum sheathing to heavy gauge metal studs





Finish: Clear Zinc				
				
 #2 Phillips  Bugle  Drill				
Gauge	Length	Thread	Quantity	Item Code
#6	1"	Fine	1000 Tub	06C100C
#6	1¼"	Fine	1000 Tub	06C125C*
#6	1¼"	Fine	4000 Box	06C125CB
#6	1½"	Fine	1000 Tub	06C162C*
#6	1½"	Fine	4000 Box	06C162CB
#6	2"	Fine	1000 Tub	06C200C*



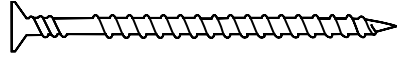

Finish: Exterior				
				
Gauge	Length	Thread	Quantity	Item Code
#6	1¼"	Fine	1000 Box	06C125WK*
#6	1½"	Fine	1000 Box	06C162WK*
#8	3"	¾ Fine	1000 Box	08C300WK



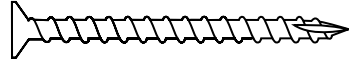

Finish: Gray Phosphate				
				
Gauge	Length	Thread	Quantity	Item Code
#6	1¼"	Fine	4000 Box	06C125PB
#6	1½"	Fine	4000 Box	06C162PB
#6	2"	Fine	4000 Box	06C200PB

Wood to Wood Screws



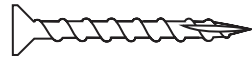

General purpose interior wood screws

Finish: Yellow Zinc				
				
 #2 Square  Flat  Sharp				
Gauge	Length	Thread	Quantity	Item Code
#8	1½"	Coarse	1000 Tub	08F150Y
#8	1¾"	⅔ Coarse	1000 Tub	08F175Y
#8	2"	⅔ Coarse	1000 Tub	08F200Y
#8	2½"	⅔ Coarse	800 Tub	08F250Y
#8	3"	⅔ Coarse	800 Tub	08F300Y
#10	2"	⅔ Coarse	800 Tub	10F200Y

Finish: Yellow Zinc				
				
 #2 Square  Flat  Type 17				
Gauge	Length	Thread	Quantity	Item Code
#8	1¾"	Coarse	4000 Box	08L175YB

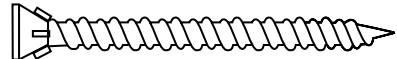



Finish: Clear Zinc				
				
 #2 Square  Flat  Type 17				
Gauge	Length	Thread	Quantity	Item Code
#8	1¾"	Coarse	4000 Box	08L125CBLCTS





Interior wood screws for harder engineered lumber and flooring materials

Finish: Yellow Zinc				
				
 #2 Square  Trim Head + Nibs  Sharp				
Gauge	Length	Thread	Quantity	Item Code
#8	2"	High Low	4000 Box	08F200YBTHSS

Underlayment Screws

Trim-head screws for underlayment, wood to wood, and crating/pallet applications

Finish: Gray Phosphate				
				
 #2 Phillips  Trim Head + Nibs  Sharp				
Gauge	Length	Thread	Quantity	Item Code
#7	1"	High Low	4000 Box	07Q100PB
#7	1¼"	High Low	4000 Box	07Q125PB

Finish: Gray Phosphate				
				
 #2 Square  Trim Head + Nibs  Sharp				
Gauge	Length	Thread	Quantity	Item Code
#7	1¼"	High Low	4000 Box	07Q125PBQ







* ICC-certified test data available on all highlighted items. Refer to ESR-3558 for details.





COLLATED SCREWS

Wood to Heavy Steel Screws

Pilot-point screw or fastening sheathing to heavy steel





Finish: Clear Zinc				
				
 #2 Square  Flat  Pilot				
Gauge	Length	Thread	Quantity	Item Code
#8	2"	Fine	1000 Box	08G200CKLFPS

Wing-drill-point-screws for fastening sheathing to heavy steel





Finish: Clear Zinc				
				
 #2 Square  Wafer + Nibs  Wing Drill				
Gauge	Length	Thread	Quantity	Item Code
#8	1 1/2"	Fine	1000 Tub	08G162CTWFWS
#10	1 1/2"	Fine	1000 Tub	10G162CTWFWS
#8	2"	Fine	1000 Tub	08G200CTWFWS
#8	2 1/2"	Fine	800 Tub	08G250CTWFWS
#8	3"	Fine	800 Tub	08G300CTWFWS

Finish: Exterior				
				
Gauge	Length	Thread	Quantity	Item Code
#8	2"	Fine	1000 Tub	08G200WTWFWS





Low-profile screws for fastening sheathing to steel

Finish: Clear Zinc				
				
 #2 Phillips  Reduced Wafer  Drill 				
Gauge	Length	Thread	Quantity	Item Code
#8	1"	Fine	1000 Box	08G100CKNFDP*





Low-profile screws for fastening sheathing to steel

Finish: Clear Zinc				
				
 #2 Square  Wafer  Drill				
Gauge	Length	Thread	Quantity	Item Code
#10	1 1/4"	Fine	4000 Box	10G125CBWFDS

Wing-drill-point screws for fastening sheathing to heavy steel structures





Finish: Yellow Zinc				
				
 Rex  Flat  Wing T3 Drill				
Gauge	Length	Thread	Quantity	Item Code
#12	1 1/4"	Fine	1000 Box	12G175YKLFAX

Wing-drill-point screws for fastening sheathing to heavy steel structures

Finish: Yellow Zinc				
				
 Rex  Flat  Wing T5 Drill				
Gauge	Length	Thread	Quantity	Item Code
#12	2"	Fine	1000 Box	12G200YKLCFX
#12	2 1/2"	Fine	1000 Box	12G250YKLCFX

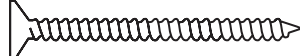



Wood to Light Steel Screws

Sharp-point screws for fastening sheathing to light steel





Finish: Clear Zinc				
				
 #2 Square  Flat  Sharp				
Gauge	Length	Thread	Quantity	Item Code
#8	1 1/2"	Double	1000 Tub	08G150CTLDSS

Cement Board Screws

Screws for fastening cement board or Hardie® board to wood

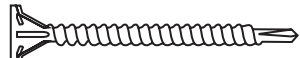



Finish: Exterior				
				
 #2 Square  Wafer + Nibs  Spoon				
Gauge	Length	Thread	Quantity	Item Code
#8	1 1/2"	High Low	1000 Tub	08T125W
#8	2"	High Low	1000 Tub	08T200W

Screws for fastening cement board or Hardie® board to steel studs

Finish: Exterior				
				
 #2 Square  Wafer + Nibs  Drill				
Gauge	Length	Thread	Quantity	Item Code
#8	1 1/2"	Fine	4000 Box	08T150WBWDFS

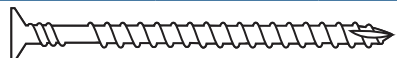
Decking and Dock Screws

Exterior wood screws for exterior projects such as decks, fencing, siding, and docks

Finish: Exterior				
				
 #2 Square  Flat  Type 17				
Gauge	Length	Thread	Quantity	Item Code
#8	1 1/4"	3/8 Coarse	1000 Tub	08D175W
#8	2"	3/8 Coarse	1000 Tub	08D200W
#8	2 1/2"	3/8 Coarse	800 Tub	08D250W
#8	3"	3/8 Coarse	800 Tub	08D300W

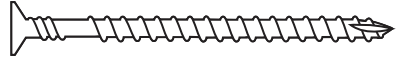



Finish: Stainless 305				
				
Gauge	Length	Thread	Quantity	Item Code
#8	2 1/2"	3/8 Coarse	800 Tub	08D250S
#9	3"	3/8 Coarse	800 Tub	09D300S



*ICC-certified test data available on all highlighted items. Refer to ESR-3558 for details.





Composite Decking Screws

Trim-head screws for fastening composite decking to wood

Finish: Exterior				
				
 #2 Square  Trim  Type 17				
Gauge	Length	Thread	Quantity	Item Code
#8	2½"	¾ Coarse	800 Tub	08R250W
#8	3"	¾ Coarse	800 Tub	08R300W

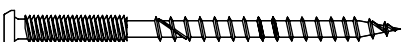
Finish: Stainless 304				
				
Gauge	Length	Thread	Quantity	Item Code
#8	2½"	¾ Coarse	800 Tub	08R250S

Specially designed cup-head screws eliminate mushrooming around screw head after installation

Finish: Exterior/Gray				
				
 #2 Square  Cupped Pan  Sharp				
Gauge	Length	Thread	Quantity	Item Code
#8	2½"	Multi-Thread	800 Tub	08S250W003
#8	3"	Multi-Thread	800 Tub	08S300W003

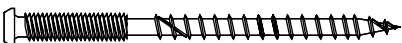
Finish: Exterior/Tan				
				
Gauge	Length	Thread	Quantity	Item Code
#8	2½"	Multi-Thread	800 Tub	08S250W592
#8	3"	Multi-Thread	800 Tub	08S300W592

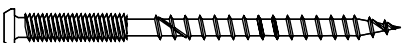
Finish: Exterior/Red				
				
Gauge	Length	Thread	Quantity	Item Code
#8	2½"	Multi-Thread	800 Tub	08S250W596
#8	3"	Multi-Thread	800 Tub	08S300W596

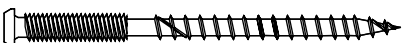



Finish: Exterior/Brown				
				
Gauge	Length	Thread	Quantity	Item Code
#8	2½"	Multi-Thread	800 Tub	08S250W497
#8	3"	Multi-Thread	800 Tub	08S300W497











* ICC-certified test data available on all highlighted items. Refer to ESR-3558 for details.





Metal to Metal Screws





General purpose metal to metal screws





Finish: Clear Zinc				
				
 #2 Square  Modified Flat Pan  Drill				
Gauge	Length	Thread	Quantity	Item Code
#10	¾"	Fine	1000 Tub	10M075CTMFDX*
#10	1"	Fine	1000 Box	10M100CKMFDX*





Finish: Clear Zinc				
				
 #2 Phillips  Reduced Wafer  Drill				
Gauge	Length	Thread	Quantity	Item Code
#10	¾"	Fine	1000 Box	10M075CKNFDX*

Finish: Yellow Zinc				
				
 Rex  Flat Pan  Drill				
Gauge	Length	Thread	Quantity	Item Code
#10	¾"	Fine	1000 Tub	10M075YTFDAX*

Finish: Yellow Zinc				
				
 Rex  Flat Pan  T4 Drill				
Gauge	Length	Thread	Quantity	Item Code
#10	¾"	22 TPI	8000 Loose	10M075YLF4X*
#10	¾"	22 TPI	1000 Box	10M075YKF4X*













Finish: Yellow Zinc				
				
 Rex  Flat Pan  T4 Drill				
Gauge	Length	Thread	Quantity	Item Code
#12	7/8"	Fine	1000 Box	12M087YKFF4X*

Finish: Yellow Zinc				
				
 Rex  Flat Pan  T3 Drill				
Gauge	Length	Thread	Quantity	Item Code
#12	1"	Fine	1000 Box	12M100YKFF3X*







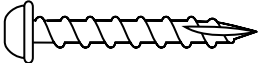

Finish: Clear Zinc				
				
 Rex  Flat Pan  Drill				
Gauge	Length	Thread	Quantity	Item Code
#10	¾"	Fine	6000 Box	10M062CBFFDX*
#12	1½"	Fine	1000 Tub	12M150CTFFDX*

COLLATED SCREWS

Light Metal Framing Screws

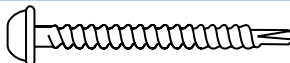
Self-tapping metal framing screw				
Finish: Gray Phosphate				
		 #2 Phillips	 Framing Pan	 Sharp
Gauge	Length	Thread	Quantity	Item Code
#7	7/16"	Double	1000 Tub	07M044PTDSP
Finish: Clear Zinc				
		 #2 Phillips	 Reduced Mod Truss	 Sharp
Gauge	Length	Thread	Quantity	Item Code
#8	1/2"	Fine	1000 Tub	08M050CTRFSP*
Self-drilling and tapping metal framing screws				
Finish: Clear Zinc				
		 #2 Phillips	 Reduced Mod Truss	 Drill
Gauge	Length	Thread	Quantity	Item Code
#8	1/2"	Fine	1000 Tub	08M050CTRFDP*

Specialty Screws

General purpose screws for a range of applications including window installation and crating				
Finish: Clear Zinc				
		 #2 Square	 Round Washer	 Type 17
Gauge	Length	Thread	Quantity	Item Code
#8	1 1/4"	Coarse	4000 Box	08X125CBACTS*
Finish: Clear Zinc				
		 #2 Square	 Round Washer	 Drill
Gauge	Length	Thread	Quantity	Item Code
#8	1 1/4"	Double	1000 Box	08X125CKADD5*
#8	2"	Double	1000 Box	08X200CKADD5*



*ICC-certified test data available on all highlighted items. Refer to ESR-3558 for details.

The New Standard in Professional Auto-Feed Screw Systems

INCREASE JOB SITE PRODUCTIVITY BY 30%!

4X faster than corded screwdrivers with loose screws*

- Duraspin Auto-Feed Screw Systems eliminate the need to reach for fasteners and position them on a magnetic screw tip.
- Duraspin allows for one-handed screw fastening with either hand, freeing the other hand to steady your work.



*DuraSpin Screw Fastening System Time & Motion Study. July, 2001. R.S.MEANS, CONSULTING SERVICES.



SCREW SYSTEM ACCESSORIES

Bits

Integrated auto-feed screw systems — 2 bits per pack			
Bits Fit	⊕ Item #	◻ Item #	⊛ Item #
DS200-AC DS202-14V DS205-14V	EA0122	EA0123	EA0269
DS212-18V DS215-18V DS232-AC DS235-AC	EA0297	EA0298	EA0299
DS275-18V DS300-AC	EA0140	EA0141	EA0270
DS312-18V DS332-AC	EA0300	EA0301	EA0302
Auto-Feed attachment kits — 2 bits per pack			
Bits Fit	⊕ Item #	◻ Item #	⊛ Item #
DS325AC DS340AC	EA0271	EA0272	EA0273
DS425AC DS440AC	EA0314	EA0315	EA0316







Bit Tips

Loose screwdriver — 10 bits per pack	
Bits Fit	⊛ Item #
SG2510 SG4100	EA0308



Bit Tips & Holders

Auto-feed screw system — 5 bit tips and 1 holder per pack		
Bit Tip Holders Fit	Item #	
DS200-AC DS202-14V DS205-14V	WC0067	
DS275-18V DS300-AC	WC0070	
Bit Tips Fit	⊕ Bit Tips Item #	◻ Bit Tips Item #
DS200-AC DS202-14V DS205-14V	EA0142	EA0143
DS275-18V DS300-AC		

Bits

Screwdriver and attachment combinations — 2 bits per pack			
	⊕ Item #	◻ Item #	⊛ Item #
SENCO SG2510 and SENC0 SG4100			
+ DS110	EA0277	EA0278	EA0279
+ DS210	EA0277	EA0278	EA0279
+ DS220	EA0311	EA0312	EA0313
+ DS310	EA0271	EA0272	EA0273
+ DS320	EA0314	EA0315	EA0316
Makita with adapters ADP019 and MB0174			
+ DS110	EA0277	EA0278	EA0279
+ DS210	EA0277	EA0278	EA0279
+ DS220	EA0311	EA0312	EA0313
+ DS310	EA0271	EA0272	EA0273
+ DS320	EA0314	EA0315	EA0316
Black & Decker, DeWalt, Hitachi, TY1800 with adapter ADP014 Makita with adapters ADP011 and ADP020			
+ DS110	EA0280	EA0281	EA0282
+ DS210	EA0280	EA0281	EA0282
+ DS220	EA0317	EA0318	EA0319
+ DS310	EA0274	EA0275	EA0276
+ DS320	EA0320	EA0321	EA0322

Adapters

For attaching screwdrivers to attachments		
Screwdriver	Fits Tools	Adapter Item #
SENCO	SG2510 SG4100	MB0173
	SG2500 SG4000	ADP015
DeWalt	DW252 DW253 DW255 DW257 DW266 DW272 DW276	ADP009
	FS2200 FS2500 FS4200 FS6200	ADP019
	FS2701	MB0174
	6805BV 6827	ADP020
	6820 6821 6823 6824 6825 68261	ADP011
HITACHI	W6V4 W6VA4 W6VB3 W6VM W6VB2	ADP010
	WH14DM	ADP017
SIOUX	Screwdrivers with 1/4" Internal Hex feature	ADP018



SCREW SYSTEM ACCESSORIES

Nosepieces

For wood applications			For drywall applications			For metal framing applications		
Fits Tools	Range	Item #	Fits Tools	Range	Item #	Fits Tools	Range	Item #
DS200-AC DS202-14V	1" - 2"	FA0211	DS200-AC DS202-14V	1" - 2"	FA0198	DS212-18V DS215-18V DS220 DS232-AC DS235-AC	½" - 1"	FB0155
DS212-18V DS215-18V DS220 DS232-AC DS235-AC	1" - 2"	FB0157	DS212-18V DS215-18V DS220 DS232-AC DS235-AC	1" - 2"	FC0878	DS212-18V DS215-18V DS220 DS232-AC DS235-AC	½" - 2"	FC0822
DS312-18V DS320 DS332-AC DS425AC DS440AC	1" - 3"	FB0159	DS312-18V DS320 DS332-AC DS425AC DS440AC	1" - 3"	FC0895	DS312-18V DS320 DS332-AC DS425AC DS440AC	½" - 2"	FC0887

Nosepieces & Metal Washers

For lath, plaster, PM, stucco, one-coat and hard-coat applications			
	Fits Tools	Range	Item #
SENCO	DS212-18V DS215-18V DS235-AC DS232-AC DS220	1" - 2"	FB0167



Metal Washer

Item #	Diameter	Box Count	Fits Screw Series
SWM125A	1¼"	1M	06A, 06B, 06C, 07A

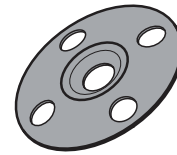

Nosepieces & Plastic Washers

For building wrap and EIFS installation			
	Fits Tools	Range	Item #
SENCO	DS312-18V DS320 DS332-AC DS425AC DS440AC	1" - 3"	FB0168



Plastic Washer

Item #	Diameter	Box Count	Fits Screw Series
SWP175A	1¼"	1M	06A, 06B, 06C, 07A (forms seal around screw)

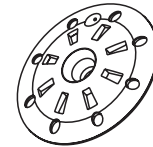

Battery Systems

Compatible with all 18V Li-Ion Duraspin II and SENC0 FUSION tools		
18V Li-Ion Battery 1.5 amp hour	Fits	
VB0155	DS212-18V DS215-18V DS312-18V All Fusion Models	<ul style="list-style-type: none"> • 1.5 amp hours • High quality reliable cells • Longer storage life • Charges 80% in 15 minutes
18V Li-Ion Battery 3.0 amp hour	Fits	
VB0161	DS212-18V DS215-18V DS312-18V All Fusion Models	<ul style="list-style-type: none"> • 3.0 amp hours • High-quality reliable cells • Longer storage life • Drives up to 2X as many fasteners as VB0155



Charger System

Can be used interchangeably with SENC0 VB0155, VB0161, and VB0118 batteries		
Battery Charger	For use with	
VB0156	VB0155 VB0161 VB0118	<ul style="list-style-type: none"> • Battery charge indicators display charge status of your battery • Compatible with all SENC0 18V Li-Ion batteries.



CORDLESS PNEUMATIC PERFORMANCE. TRIM ALL-DAY.

Experience award-winning cordless convenience in an all-day, everyday trim tool. Available in 15, 16, and 18 gauge, Fusion tools from SENCO feature a revolutionary cordless air-power technology.

- Instant shot with no ramp-up time
- No hose, compressor or fuel cell
- Drives like a pneumatic
- For professional finish & trim

In a recent industry-wide test, the Fusion F-15 was named the top cordless nail gun, highlighting its rapid rate of fire, consistent nail-driving performance in any material and its lightweight, slim-handle design.

APPLICATIONS

Finish and trim, fine woodworking, cabinet, furniture, decorative trim

FEATURES

- Rugged aluminum magazine
- Selectable drive switch
- Nose-mounted LED light
- Adjustable belt hook
- Thumbwheel depth-of-drive
- EZ-Clear feature for quickly clearing jams
- Includes storage bag and charger



F-18

2 1/8" CORDLESS STRAIGHT BRAD NAILER

ITEM# 6E0001N



18^{GA}

Features

- Thumbwheel depth-of-drive
- Nose-mounted LED light
- Rapid-charge battery reaches 80% in just 15 minutes

F-16S

2 1/2" CORDLESS STRAIGHT FINISH NAILER

ITEM# 6U0001N



16^{GA}

Features

- Thumbwheel depth-of-drive
- Nose-mounted LED light
- Rapid-charge battery reaches 80% in just 15 minutes

F-16A

2 1/2" CORDLESS ANGLED FINISH NAILER

ITEM# 5P0001N



16^{GA}
20°

Features

- Thumbwheel depth-of-drive
- Nose-mounted LED light
- Rapid-charge battery reaches 80% in just 15 minutes

F-15

2 1/2" CORDLESS ANGLED FINISH NAILER

ITEM# 5N0001N



15^{GA}
34°

Features

- Thumbwheel depth-of-drive
- Nose-mounted LED light
- Rapid-charge battery reaches 80% in just 15 minutes

One Common Battery Platform

SENCO'S 18-Volt Li-Ion Battery System

Designed for long running times with quick recharges and operates at full speed until depleted, so there is no gradual drop in power during use. Special LED fuel gauge displays battery life at the touch of a button.

18V Li-Ion Battery 1.5 amp hours	Fits
VB0155	F-18 F-16S / F-16A F-15
18V Li-Ion Battery 3.0 amp hour	Fits
VB0161	F-18 F-16S / F-16A F-15
Battery Charger	For use with
VB0156	VB0155 VB0161 VB0118



SENCO's 18-Volt Li-Ion batteries works for all Fusion Finish Nailers and all Cordless Duraspin Auto-Feed Screw Systems. See the complete SENCO Battery Platform in the accessories section on page 80.

Works with DS215-18V, DS212-18V and DS312-18V models.

Product Reference Chart

TOOL SPECS	F-18	F-16S	F-16A	F-15
Weight	6 lbs (2.72 kg)	6 lbs (2.72 kg)	6.2 lbs (2.81 kg)	6.2 lbs (2.81 kg)
Height	13" (330 mm)	13" (330 mm)	13" (330 mm)	13" (330 mm)
Length	11" (276 mm)	11" (276 mm)	13" (330 mm)	13" (330 mm)
Width	3" (76 mm)	3" (76 mm)	3" (76 mm)	3" (76 mm)
Charger	80% in 15 minutes, 100% in 45 minutes.			
Warranty	2 yrs	2 yrs	2 yrs	2 yrs
FASTENER SPECS	Fasteners are located on pages 16 - 17			
Gauge	18	16	16	15
Range for Length	5/8"-2 1/8"	3/4"-2 1/2"	1 1/4"-2 1/2"	1 1/4"-2 1/2"
Capacity	110	110	110	110
Angle/Collation	Straight Glued Strip	Straight Glued Strip	20° Angled Glued Strip	34° Angled Taped Strip
Series	AY, AX	MO	RH	DA
TOOL FEATURES				
Patented Instant Shot Design	Yes	Yes	Yes	Yes
Tool-Free Depth-of-Drive	Yes	Yes	Yes	Yes
EZ-Clear Jam Clearing	Yes	Yes	Yes	Yes
Trigger Actuation	Sequential or Contact	Sequential or Contact	Sequential or Contact	Sequential or Contact
Aluminum Drive Cylinder	Yes	Yes	Yes	Yes
Belt Hook	Adjustable and Reversible	Adjustable and Reversible	Adjustable and Reversible	Adjustable and Reversible

18^{GA} Slight-Head Brad Nails

Cabinets, decorative trim, picture frames and ornaments

Length	Point	Head	Finish	Coating	Collation	Box Count	Item Code
5/8"	Chisel	Slight	Galv	Plain	Straight Glued Strip	5M	AY10EAA
3/4"	Chisel	Slight	Galv	Plain	Straight Glued Strip	5M	AY11EAA
1"	Chisel	Slight	Galv	Plain	Straight Glued Strip	5M	AY13EAA

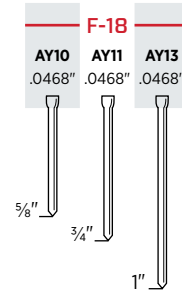

18^{GA} Straight-Strip Brad Nails

Cabinets, decorative trim, picture frames and ornaments

Length	Point	Head	Finish	Coating	Collation	Box Count	Item Code
5/8"	Chisel	Medium	Galv	Plain	Straight Glued Strip	5M	AX10EAA
3/4"	Chisel	Medium	Galv	Plain	Straight Glued Strip	5M	AX11EAA
1"	Chisel	Medium	Galv	Plain	Straight Glued Strip	5M	AX13EAA
1 1/4"	Chisel	Medium	Galv	Plain	Straight Glued Strip	5M	AX15EAA
1 1/2"	Chisel	Medium	Galv	Plain	Straight Glued Strip	5M	AX17EAA
1 5/8"	Chisel	Medium	Galv	Plain	Straight Glued Strip	5M	AX18EAA
1 3/4"	Chisel	Medium	Galv	Plain	Straight Glued Strip	5M	AX19EAA
2"	Chisel	Medium	Galv	Plain	Straight Glued Strip	5M	AX21EAA
2 1/8"	Chisel	Medium	Galv	Plain	Straight Glued Strip	5M	AX22EAA
1"	Chisel	Medium	Galv	Plain	Straight Glued Strip	1M (CS)	A201009
1 1/4"	Chisel	Medium	Galv	Plain	Straight Glued Strip	1M (CS)	A201259
1 1/2"	Chisel	Medium	Galv	Plain	Straight Glued Strip	0.8M (CS)	A201509
2"	Chisel	Medium	Galv	Plain	Straight Glued Strip	0.8M (CS)	A202009
5/8-1 1/4"	Chisel	Medium	Galv	Plain	Straight Glued Strip	1.2M (CS)	A209809
1-2"	Chisel	Medium	Galv	Plain	Straight Glued Strip	1.2M (CS)	A209909
1"	Chisel	Medium	Stainless	Plain	Straight Glued Strip	1M (CS)	AX13EGAR
1 1/4"	Chisel	Medium	Stainless	Plain	Straight Glued Strip	1M (CS)	AX15EGAR
1 1/2"	Chisel	Medium	Stainless	Plain	Straight Glued Strip	1M (CS)	AX17EGAR
2"	Chisel	Medium	Stainless	Plain	Straight Glued Strip	1M (CS)	AX21EGAR

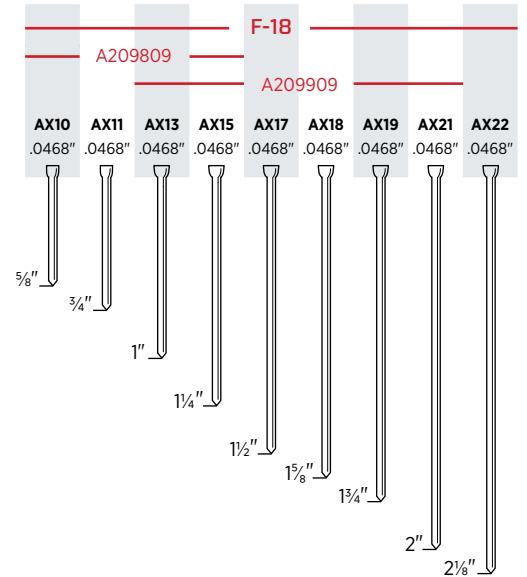

CS-Clamshell

16^{GA} Straight-Strip Finish Nails

Furniture and cabinets, molding and trim, baseboard, chair rails, window casings and upholstery trim panels

Length	Point	Head	Finish	Coating	Collation	Box Count	Item Code
3/4"	Chisel	T-head	Galv	Plain	Straight Glued Strip	2M	M001000
1"	Chisel	T-head	Galv	Plain	Straight Glued Strip	2M (PT)	M001001
1 1/4"	Chisel	T-head	Galv	Plain	Straight Glued Strip	2M (PT)	M001002
1 1/2"	Chisel	T-head	Galv	Plain	Straight Glued Strip	2M (PT)	M001003
1 3/4"	Chisel	T-head	Galv	Plain	Straight Glued Strip	2M (PT)	M001004
2"	Chisel	T-head	Galv	Plain	Straight Glued Strip	2M (PT)	M001005
2 1/2"	Chisel	T-head	Galv	Plain	Straight Glued Strip	2M (PT)	M001007
1"	Chisel	T-head	Galv	Plain	Straight Glued Strip	1.2M (CS)	A401009
1 1/4"	Chisel	T-head	Galv	Plain	Straight Glued Strip	1.2M (CS)	A401259
1 1/2"	Chisel	T-head	Galv	Plain	Straight Glued Strip	0.7M (CS)	A401509
1 3/4"	Chisel	T-head	Galv	Plain	Straight Glued Strip	0.7M (CS)	A401759
2"	Chisel	T-head	Galv	Plain	Straight Glued Strip	0.7M (CS)	A402009
2 1/2"	Chisel	T-head	Galv	Plain	Straight Glued Strip	0.7M (CS)	A402509
1 1/4"-2 1/2"	Chisel	T-head	Galv	Plain	Straight Glued Strip	0.8M (CS)	A409809
1 1/2"	Chisel	T-head	Stainless	Plain	Straight Glued Strip	0.7M	M001003GR
2"	Chisel	T-head	Stainless	Plain	Straight Glued Strip	0.7M	M001005GR
2 1/2"	Chisel	T-head	Stainless	Plain	Straight Glued Strip	0.7M	M001007GR

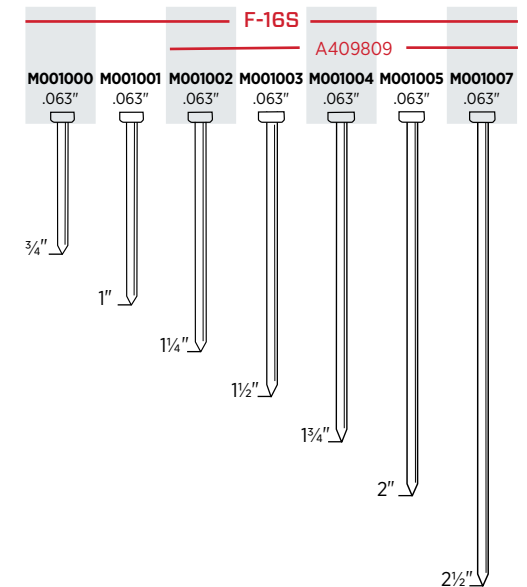

CS-Clamshell, PT-Plastic Tub

FUSION FASTENERS

16^{GA}
20°

Angled-Strip Finish Nails*

Furniture and cabinets, molding and trim, baseboard, chair rail, window casings and upholstery trim panels

Length	Point	Head	Finish	Coating	Collation	Box Count	Item Code
1/4"	Chisel	T-head	Galv	Plain	20° Angled Glued Strip	2M (PT)	RH15EAA
1/2"	Chisel	T-head	Galv	Plain	20° Angled Glued Strip	2M (PT)	RH17EAA
3/4"	Chisel	T-head	Galv	Plain	20° Angled Glued Strip	2M (PT)	RH19EAA
2"	Chisel	T-head	Galv	Plain	20° Angled Glued Strip	2M (PT)	RH21EAA
2 1/2"	Chisel	T-head	Galv	Plain	20° Angled Glued Strip	2M (PT)	RH25EAA

PT-Plastic Tub

*NOTE: ONLY Fits 16 Gauge /20° Finish Nailers

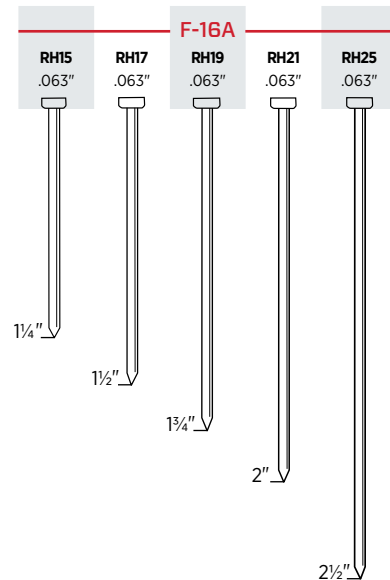

15^{GA}
34°

Angled-Strip Finish Nails

Furniture and cabinets, molding and trim, baseboard, chair rail, doors and window casings

Length	Point	Head	Finish	Coating	Collation	Box Count	Item Code
1"	Chisel	Brad	Bright	Sencote	34° Angled Taped Strip	4M	DA13EPBN
1 1/4"	Chisel	Brad	Bright	Sencote	34° Angled Taped Strip	4M	DA15EPBN
1 1/2"	Chisel	Brad	Bright	Sencote	34° Angled Taped Strip	4M	DA17EPBN
1 3/4"	Chisel	Brad	Bright	Sencote	34° Angled Taped Strip	4M	DA19EPBN
2"	Chisel	Brad	Bright	Sencote	34° Angled Taped Strip	4M	DA21EPBN
2 1/4"	Chisel	Brad	Bright	Sencote	34° Angled Taped Strip	4M	DA23EPBN
2 1/2"	Chisel	Brad	Bright	Sencote	34° Angled Taped Strip	3M	DA25EPB
1 1/2"	Chisel	Brad	Bright	Sencote	34° Angled Taped Strip	0.7M (CS)	A301500
1 3/4"	Chisel	Brad	Bright	Sencote	34° Angled Taped Strip	0.7M (CS)	A301750
2"	Chisel	Brad	Bright	Sencote	34° Angled Taped Strip	0.7M (CS)	A302000
2 1/2"	Chisel	Brad	Bright	Sencote	34° Angled Taped Strip	0.7M (CS)	A302500
1 1/4"	Chisel	Brad	Galv	Sencote	34° Angled Taped Strip	4M	DA15EABN
1 1/2"	Chisel	Brad	Galv	Sencote	34° Angled Taped Strip	4M	DA17EABN
1 3/4"	Chisel	Brad	Galv	Sencote	34° Angled Taped Strip	4M	DA19EABN
2"	Chisel	Brad	Galv	Sencote	34° Angled Taped Strip	4M	DA21EABN
2 1/2"	Chisel	Brad	Galv	Sencote	34° Angled Taped Strip	3M	DA25EAB
2"	Chisel	Brad	Galv	Sencote	34° Angled Taped Strip	0.7M (CS)	A302009
2 1/2"	Chisel	Brad	Galv	Sencote	34° Angled Taped Strip	0.7M (CS)	A302509
2"	Chisel	Brad	Stainless	Sencote	34° Angled Taped Strip	2M	DA21EGBN
2 1/2"	Chisel	Brad	Stainless	Sencote	34° Angled Taped Strip	1.2M	DA25EGB
1 1/4"	Diamond	Brad	Hardened*	Plain	34° Angled Taped Strip	4M	DA15AIA
1 1/2"	Diamond	Brad	Hardened*	Plain	34° Angled Taped Strip	4M	DA17AIA
1 3/4"	Diamond	Brad	Hardened*	Plain	34° Angled Taped Strip	4M	DA19AIA

CS-Clamshell

*Hardened regular galvanized heat treated 15 Gauge for steel stud and trim

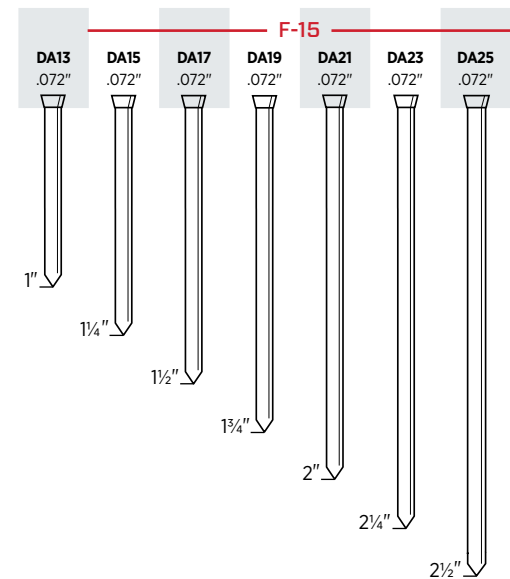

Maximize Your Fusion Cordless Convenience.

SENCO® manufactures 62 varieties of finish nails available in 6 gauges and 12 lengths.



FINISH & WOODWORKING

THE DIFFERENCE IS IN THE DETAILS

SENCO is the industry standard in tools for finish and fine woodworking, providing compact, ultra-light, easy-to-use tools designed for precision and longevity.

We offer a broader range of tools than anyone else, covering 15-23 gauge nailers and 15-18 gauge staplers including the award-winning 21 gauge FinishPro®21LXP.

APPLICATIONS

Cabinetry, furniture, decorative trim, crown molding, custom woodworking applications and all other finish needs

FEATURES

- EZ-Clear™ latch to clear jams fast
- No-Mar pads to protect woodwork
- Clear line-of-sight for precision fastening
- Comfort grip
- Adjustable depth-of-drive
- Widest range of finish-gauge fasteners

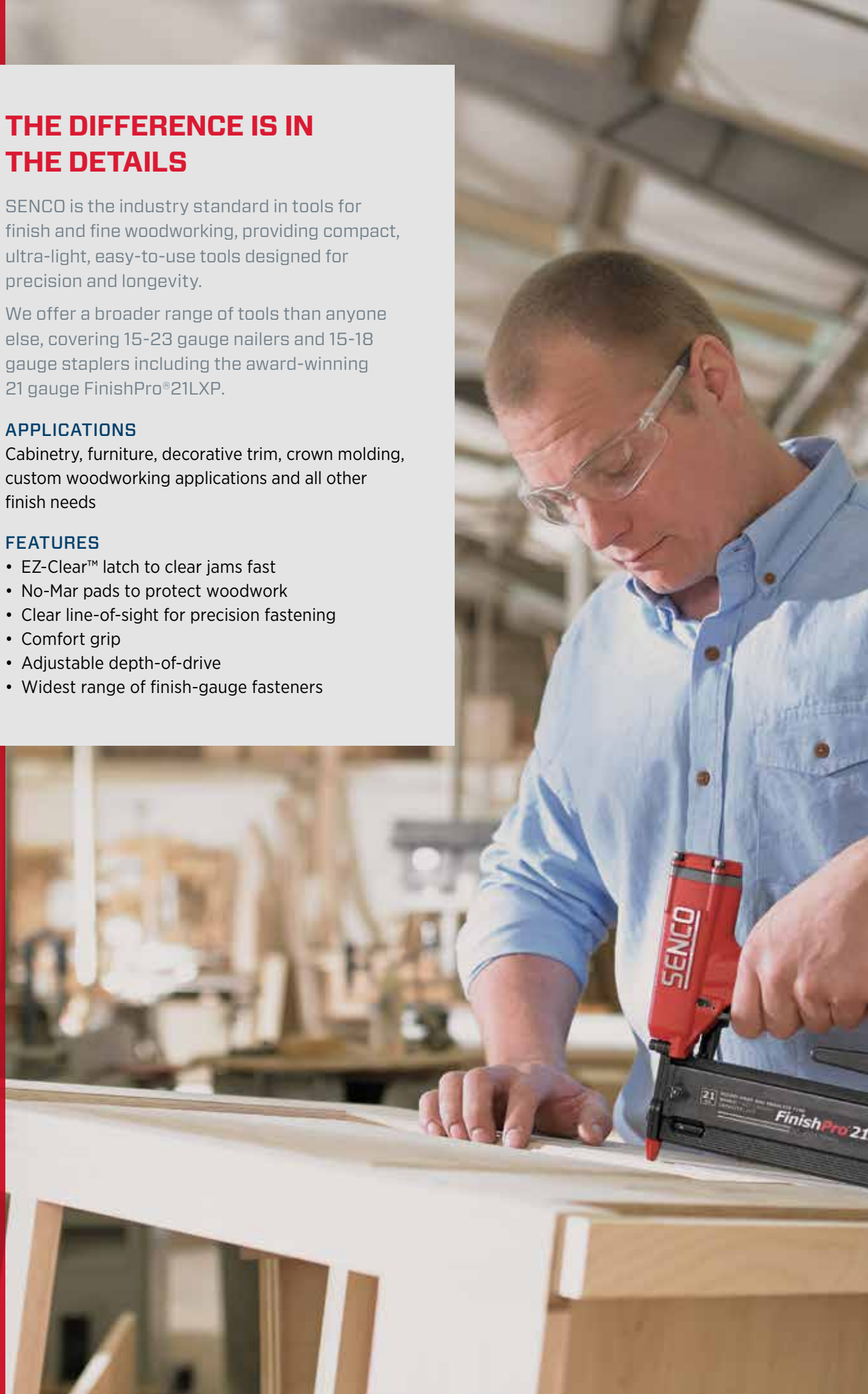

FinishPro® 23SXP

1 3/8" HEADLESS PINNER

ITEM# 8F0001N

23_{GA}



Features

- Powerful — ensures complete drives into hard substrates
- Automatically adjusts for different fastener lengths
- Ergonomic handle for all-day comfort
- Ultra-narrow nose for tight corners
- Includes case, swivel air plug, wrench and tool oil

FinishPro® 23LXP

2" HEADLESS PINNER

ITEM# 8L0001N

23_{GA}



Features

- Most powerful tool in its class — ensures complete drives into hard substrates
- Automatically adjusts for different fastener lengths
- Ergonomic handle for all-day comfort
- Ultra-narrow nose for tight corners
- Includes case, swivel air plug, wrench and tool oil

FinishPro® 21LXP

2" PINNER

ITEM# 8M0001N

21_{GA}



Features

- Powerful — ensures complete drives into hard substrates
- Automatically adjusts for different fastener lengths
- Ergonomic handle for all-day comfort
- Ultra-narrow nose for tight corners
- Includes case, swivel air plug, wrench and tool oil

Pins and Brads: 23, 21 & 18 Gauge The New Standard When Details Matters.



Product Reference Chart

TOOL SPECS	FinishPro®23SXP	FinishPro®23LXP	FinishPro®21LXP
Trigger	Sequential	Sequential	Sequential
Op. Pressure	70-120 psi (4.8-8.3 bar) 1.1	70-120 psi (4.8-8.3 bar)	70 - 120 psi (4.8-8.3 bar)
Air Consumption (60 CPM)	scfm	1.1 scfm	1.1 scfm
Air Inlet	1/4" NPT	1/4" NPT	1/4" NPT
Weight	2.5 lbs (1.1 kg)	2.7 lbs (1.2 kg)	2.7 lbs (1.2 kg)
Height	7.56" (192 mm)	8.89" (226 mm)	8.89" (226 mm)
Length	7.87" (200 mm)	7.87" (200 mm)	7.87" (200 mm)
Width	1.85" (44 mm)	1.85" (44 mm)	1.85" (44 mm)
Main Body Material	Aluminum	Aluminum	Aluminum
Warranty	5 yrs	5 yrs	5 yrs
FASTENER SPECS	Fasteners are located on pages 24 - 29		
Capacity	126	126	170
Range	1/2"-1 3/8"	1/2"-2"	5/8"-2"
Gauge/Collation	23 Ga. Straight Glued Strip	23 Ga. Straight Glued Strip	21 Ga. Straight Glued Strip
Series	A10, CZ	A10, CZ	ZX
TOOL FEATURES			
Tool-Free Depth-of-Drive	No	No	No
Belt Hook	Yes	Yes	Yes
Oil-less	No	No	No
Exhaust	Rear	Rear	Rear

FinishPro®18Mg

2 1/8" BRAD NAILER

ITEM# 1U0021N

18_{GA}



Features

- Metal cylinder for increased durability
- EZ-Clear™ latch virtually eliminates downtime caused by fastener jams
- Narrow nose for tight corners
- Includes case, swivel air plug and wrench

SLP20XP

1 5/8" BRAD NAILER

ITEM# 430101N

18_{GA}



Features

- Never-Lube® design — no oil required
- Drives both slight- and medium-headed brads
- Muffler ensures quieter operation
- Includes case

FinishPro®25XP

2 1/8" BRAD NAILER

ITEM# 760102N

18_{GA}



Features

- Never-Lube® design — no oil required
- Drives both slight- and medium-headed brads
- Powerful — ensures complete drives into hard substrates
- Includes case

FinishPro®32

2 1/2" FINISH NAILER

ITEM# 1X0201N

16_{GA}



Features

- EZ-Clear™ latch virtually eliminates downtime caused by fastener jams
- Piston and driver designed for durability
- Reversed safety element for improved line of sight
- Includes case

Product Reference Chart

TOOL SPECS	FinishPro®18Mg	SLP20XP	FinishPro®25XP	FinishPro®32
Trigger	Selectable	Sequential	Sequential	Sequential
Op. Pressure	70-120 psi (4.8-8.3 bar)	70-120 psi (4.8-8.3 bar)	70-120 psi (4.8-8.3 bar)	70 - 120 psi (4.8 - 8.3 bar)
Air Consumption (60 CPM)	2.4 scfm	1.92 scfm	1.92 scfm	2.16 scfm
Air Inlet	1/4" NPT	1/4" NPT	1/4" NPT	1/4" NPT
Weight	2.48 lbs (1.12 kg)	2.3 lbs (1 kg)	2.7 lbs (1.2 kg)	4.2 lbs (1.9 kg)
Height	9.75" (248 mm)	8.25" (210 mm)	9.9" (251 mm)	10.88" (276 mm)
Length	10.5" (267 mm)	9.5" (241 mm)	9.8" (249 mm)	12.16" (307 mm)
Width	2.5" (63.5 mm)	2" (50.8 mm)	2.2" (56 mm)	3" (76 mm)
Main Body Material	Magnesium	Aluminum	Aluminum	Aluminum
Warranty	5 yrs	5 yrs	5 yrs	5 yrs
FASTENER SPECS	Fasteners are located on pages 24 - 29			
Capacity	110	110	110	110
Range	5/8"-2 1/8"	5/8"-1 5/8"	5/8"-2 1/8"	1 1/4" - 2 1/2"
Gauge/Collation	18 Ga. Straight Glued Strip	18 Ga. Straight Glued Strip	18 Ga. Straight Glued Strip	16 Ga. Straight Glued Strip
Series	AX	AX, AY	AX, AY	A4, MO
TOOL FEATURES				
Tool-Free Depth-of-Drive	Yes	No	Yes	Yes
Belt Hook	Yes	No	Yes	Yes
Oil-Less	Yes	Yes	Yes	No
Exhaust	Rear Adjustable	Fixed	Adjustable	Adjustable

FinishPro® 33Mg

2½" ANGLED FINISH NAILER

ITEM# 6F0001N



16^{GA}
20°

Features

- EZ-Clear™ latch virtually eliminates downtime caused by fastener jams
- Integrated air blower clears debris from work surface
- Metal cylinder for increased durability
- Includes case, swivel air plug and wrench

SFN30

2" ANGLED FINISH NAILER

ITEM# 620002N



15^{GA}
34°

Features

- Never-Lube® design — no oil required
- EZ-Clear™ latch virtually eliminates downtime caused by fastener jams
- Ultra-lightweight for ease of use and maneuverability
- Includes case

FinishPro® 35Mg

2½" ANGLED FINISH NAILER

ITEM# 6G0001N



15^{GA}
34°

Features

- EZ-Clear™ latch virtually eliminates downtime caused by fastener jams
- Integrated air blower clears debris from work surface
- Metal cylinder for increased durability
- Includes case, swivel air plug and wrench

FinishPro® 42XP

2½" ANGLED FINISH NAILER

ITEM# 4G0001N



15^{GA}
34°

Features

- Never-Lube® design — no oil required
- EZ-Clear™ latch virtually eliminates downtime caused by fastener jams
- High-strength driver with threaded connection
- Metal cylinder for increased durability
- Includes case, belt hook and contact trigger kit

Product Reference Chart

TOOL SPECS	FinishPro®33Mg	SFN30	FinishPro®35Mg	FinishPro®42XP
Trigger	Selectable	Sequential	Sequential	Sequential
Op. Pressure	70-120 psi (4.8-8.3 bar)	70-120 psi (4.8-8.3 bar)	70-120 psi (4.8-8.3 bar)	70-120 psi (4.8-8.3 bar)
Air Consumption (60 CPM)	2.22 scfm	2.16 scfm	3.2 scfm	3.87 scfm
Air Inlet	¼" NPT	¼" NPT	¼" NPT	¼" NPT
Weight	3.83 lbs (1.74 kg)	3.6 lbs (1.6 kg)	4.65 lbs (2.1 kg)	4.7 lbs (2.1 kg)
Height	11.5" (292 mm)	9.62" (244 mm)	12.25" (311 mm)	11.25" (286 mm)
Length	12" (305 mm)	12" (305 mm)	13" (330 mm)	13" (330 mm)
Width	3" (76 mm)	3.25" (82.5 mm)	3.4" (89.6 mm)	3.5" (89 mm)
Main Body Material	Magnesium	Composite	Magnesium	Magnesium
Warranty	5 yrs	5 yrs	5 yrs	5 yrs
FASTENER SPECS	Fasteners are located on pages 24 - 29			
Capacity	110	104	110	104
Range	1¼"-2½"	1"-2"	1¼"-2½"	1¼"-2½"
Gauge/Collation	16 Ga. 20° Angled Strip	15 Ga. 34° Angled Taped Strip	15 Ga. 34° Angled Taped Strip	15 Ga. 34° Angled Taped Strip
Series	RH	DA	DA	DA
TOOL FEATURES				
Tool-Free Depth-of-Drive	Yes	Yes	Yes	Yes
Belt Hook	Yes	Yes	Yes	Yes
Oil-Less	Yes	Yes	Yes	Yes
Exhaust	Adjustable	Fixed	Adjustable	Adjustable

SLS20XP

3/16", 1/4", 3/8" CROWNS, 1 1/2" FINE/MED WIRE STAPLER

SEE ITEM# CHART

19_{GA} 18_{GA}



Features

- Never-Lube® design — no oil required
- Ultra-lightweight for ease of use and maneuverability
- Metal cylinder for increased durability
- Muffler ensures quieter operation

SLS25XP

1/4", 3/8" CROWNS, 1 1/2" MEDIUM WIRE STAPLER

SEE ITEM# CHART

18_{GA}



Features

- Never-Lube® design — no oil required
- Ultra-lightweight for ease of use and maneuverability
- Metal cylinder for increased durability
- Muffler ensures quieter operation

SKSXP

1/4", 3/8", 7/16" CROWNS, 1 1/2" MED/HEAVY WIRE STAPLER

SEE ITEM# CHART

18_{GA} 16_{GA}



Features

- Never-Lube® design — no oil required
- EZ-Clear™ latch virtually eliminates downtime caused by fastener jams
- Long 1" lip to get into tight spots

SLS20XP, SLS25XP and SKSXP Item# Chart

Model	Item Code
SLS20XP-K	490101N
SLS20XP-L	490103N
SLS20XP-L W/CASE	490105N
SLS20XP-L SENCOMATIC	490015N
SLS20XP-M SENCOMATIC	490009N
SLS20XP-M	490107N
SLS20XP-R	490111N
SLS25XP-L	820103N
SLS25XP-M	820107N
SKSXP-L	300120N
SKSXP-M	300152N
SKSXP-N	300184N

Product Reference Chart

TOOL SPECS	SLS20XP	SLS25XP	SKSXP
Trigger	Sequential	Contact	Sequential
Op. Pressure	70-120 psi (4.8-8.3 bar)	70-120 psi (4.8-8.3 bar)	70-120 psi (4.8-8.3 bar)
Air Consumption (60 CPM)	1.92 scfm	1.92 scfm	2.16 scfm
Air Inlet	1/4" NPT	1/4" NPT	1/4" NPT
Weight	2.5 lbs (1.13 kg)	2.67 lbs (1.21 kg)	4.2 lbs (1.9 kg)
Height	8.5" (216 mm)	9" (229 mm)	9.25" (238 mm)
Length	12" (305 mm)	12" (305 mm)	12.38" (314 mm)
Width	2.5" (63.5 mm)	2" (50.8 mm)	3" (76 mm)
Main Body Material	Aluminum	Aluminum	Aluminum
Warranty	5 yrs	5 yrs	5 yrs
FASTENER SPECS	Fasteners are located on pages 24 - 29		
Capacity	168	168	145
Range	3/8"-1 1/2"	3/8"-1 1/2"	3/4"-1 1/2"
Crown	3/16", 1/4", 3/8"	1/4", 3/8"	1/4", 3/8", 7/16"
Gauge/Collation	19, 18 Ga. Straight Glued Strip	18 Ga. Straight Glued Strip	18, 16 Ga. Straight Glued Strip
Series	K, L, M, R	L, M	L, M, N
TOOL FEATURES			
Tool-Free Depth-of-Drive	Tool required	Tool required	No
Belt Hook	No	No	No
Oil-Less	Yes	Yes	Yes

SLS150Mg

¼" CROWN, 1916' MEDIUM WIRE STAPLER

ITEM# 8C0001N

18_{GA}



Features

- Ultra-lightweight for ease of use and maneuverability
- Nose-mounted LED light — illuminates work surface
- Durable composite magazine
- Reload indicator on magazine
- Includes case and wrench

SLS18Mg

¼" CROWN, 1½" MEDIUM WIRE STAPLER

ITEM# 1W0021N

18_{GA}



Features

- Ultra-lightweight for ease of use and maneuverability
- Metal cylinder for increased durability
- Reload indicator on magazine
- Includes case, swivel air plug and wrench

SC1XP Senclamp®

7/16" CROWN, 916' SENCLAMP® FASTENER

ITEM# 220101N, CYCLE-THRU MODEL ITEM# 4E0002N

25_{GA}



Features

- Senclamp® fasteners pull the joint together during driving for a tight, permanent fit
- Eliminates milling, doweling, clamping, screwing and other time-consuming, cost-adding operations
- The Senclamp high-carbon steel fastener derives added strength from its special webbed design

SC2 Sencor®

1" CROWN, ½" CORRUGATED STAPLER

ITEM# 470001N

25_{GA}



Features

- Powerful – ensures complete drives into hard substrates
- Eliminates gluing, milling, doweling, screwing and clamping
- Added strength for larger butt joints

Product Reference Chart

TOOL SPECS	SLS150MG	SLS18MG	SC1XP Senclamp®	SC2 Sencor®
Trigger	Selectable	Selectable	Sequential	Sequential
Op. Pressure	70-120 psi (4.8-8.3 bar)	70-120 psi (4.8-8.3 bar)	80-110 psi (5.5-7.5 bar)	80-110 psi (5.5-7.5 bar)
Air Consumption (60 CPM)	2.4 scfm	2.4 scfm	3.8 scfm	3.7 scfm
Air Inlet	¼" NPT	¼" NPT	⅜" NPT	⅜" NPT
Weight	2.6 lbs (1.8 kg)	2.6 lbs (1.8 kg)	6.3 lbs (2.8 kg)	6.9 lbs (3.1 kg)
Height	9.5" (241 mm)	9.5" (241 mm)	9.8" (249 mm)	9.44" (240 mm)
Length	10.25" (260 mm)	10.25" (260 mm)	12.7" (322 mm)	12.5" (318 mm)
Width	2.5" (63.5 mm)	2.5" (63.5 mm)	2.5" (63.5 mm)	2" (50.8 mm)
Main Body Material	Magnesium	Magnesium	Aluminum	Aluminum
Warranty	5 yrs	5 yrs	5 yrs	5 yrs
FASTENER SPECS	Fasteners are located on pages 24 - 29			
Capacity	110	110	120	80
Range	½"-1⅜"	⅜"-1½"	⅝"-⅞"	¼"-½"
Crown	¼"	¼"	⅞"	1"
Gauge/Collation	18 Ga. Straight Glued & Taped Strip	18 Ga. Straight Glued & Taped Strip	25 Ga. Straight Glued Strip	25 Ga. Straight Glued Strip
Series	L	L	Y	X
TOOL FEATURES				
Tool-Free Depth-of-Drive	Yes	Yes	No	No
Belt Hook	Yes	Yes	No	No
Oil-Less	Yes	Yes	No	No

23^{GA}

Headless Straight-Strip Pins

Pins fasten the smallest of trim securely, leaving a nearly invisible hole

Length	Point	Head	Finish	Coating	Collation	Box Count	Item Code
1/2"	Chisel	Headless	Galv	Plain	Straight Glued Strip	15.5M	CZ08EAA
5/8"	Chisel	Headless	Galv	Plain	Straight Glued Strip	15.5M	CZ10EAA
3/4"	Chisel	Headless	Galv	Plain	Straight Glued Strip	15.5M	CZ11EAA
1/2"	Chisel	Headless	Galv	Plain	Straight Glued Strip	2.6M (CS)	A100509
5/8"	Chisel	Headless	Galv	Plain	Straight Glued Strip	2.6M (CS)	A100629
3/4"	Chisel	Headless	Galv	Plain	Straight Glued Strip	2.6M (CS)	A100759
1"	Chisel	Headless	Galv	Plain	Straight Glued Strip	2.6M (CS)	A101009
1 1/4"	Chisel	Headless	Galv	Plain	Straight Glued Strip	2.6M (CS)	A101259
1 3/8"	Chisel	Headless	Galv	Plain	Straight Glued Strip	2.6M (CS)	A101379
1 1/2"	Chisel	Headless	Galv	Plain	Straight Glued Strip	2.6M (CS)	A101509
2"	Chisel	Headless	Galv	Plain	Straight Glued Strip	2.6M (CS)	A102009
1 1/2" - 1"	Chisel	Headless	Galv	Plain	Straight Glued Strip	2.5M (CS)	A109809
1" - 2"	Chisel	Headless	Galv	Plain	Straight Glued Strip	2.5M (CS)	A109909

CS-Clamshell

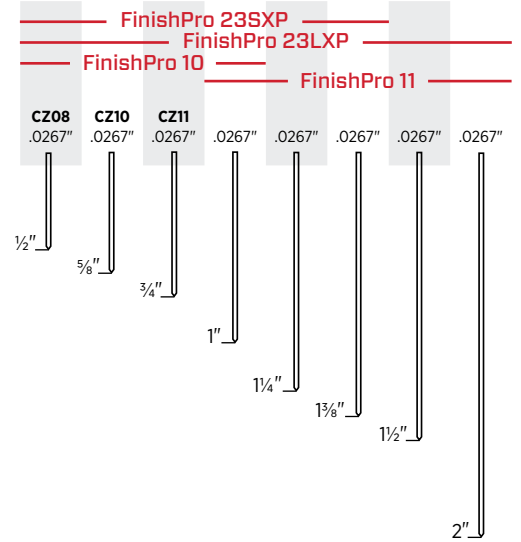

21^{GA}

Medium Straight-Strip Head Pins

21 gauge pins offer significantly more holding power than 23 gauge pins while leaving a much smaller indent than an 18 gauge brad

Length	Point	Head	Finish	Coating	Collation	Box Count	Item Code
5/8"	Chisel	Medium	Galv	Plain	Straight Glued Strip	5M	ZX10EAA
1"	Chisel	Medium	Galv	Plain	Straight Glued Strip	5M	ZX13EAA
1 3/8"	Chisel	Medium	Galv	Plain	Straight Glued Strip	5M	ZX16EAA
1 1/2"	Chisel	Medium	Galv	Plain	Straight Glued Strip	5M	ZX18EAA
2"	Chisel	Medium	Galv	Plain	Straight Glued Strip	5M	ZX21EAA
5/8"	Chisel	Medium	Galv	Plain	Straight Glued Strip	1M (CS)	ZX10EAANR
1"	Chisel	Medium	Galv	Plain	Straight Glued Strip	1M (CS)	ZX13EAANR
1 3/8"	Chisel	Medium	Galv	Plain	Straight Glued Strip	1M (CS)	ZX16EAANR
1 1/2"	Chisel	Medium	Galv	Plain	Straight Glued Strip	0.8M (CS)	ZX18EAANR
2"	Chisel	Medium	Galv	Plain	Straight Glued Strip	0.8M (CS)	ZX21EAANR

CS-Clamshell

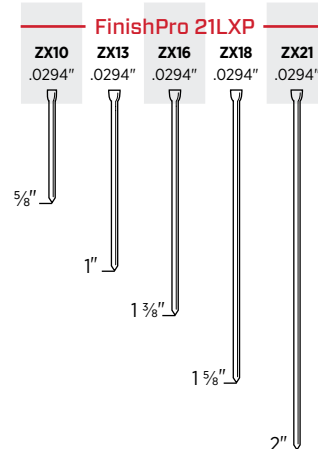

18^{GA}

Straight Strip-Brad Nails

Cabinets, decorative trim, picture frames and ornaments

Length	Point	Head	Finish	Coating	Collation	Box Count	Item Code
5/8"	Chisel	Medium	Galv	Plain	Straight Glued Strip	5M	AX10EAA
3/4"	Chisel	Medium	Galv	Plain	Straight Glued Strip	5M	AX11EAA
1"	Chisel	Medium	Galv	Plain	Straight Glued Strip	5M	AX13EAA
1 1/4"	Chisel	Medium	Galv	Plain	Straight Glued Strip	5M	AX15EAA
1 1/2"	Chisel	Medium	Galv	Plain	Straight Glued Strip	5M	AX17EAA
1 3/8"	Chisel	Medium	Galv	Plain	Straight Glued Strip	5M	AX18EAA
1 3/4"	Chisel	Medium	Galv	Plain	Straight Glued Strip	5M	AX19EAA
2"	Chisel	Medium	Galv	Plain	Straight Glued Strip	5M	AX21EAA
2 1/2"	Chisel	Medium	Galv	Plain	Straight Glued Strip	5M	AX22EAA
1"	Chisel	Medium	Galv	Plain	Straight Glued Strip	1M (CS)	A201009
1 1/4"	Chisel	Medium	Galv	Plain	Straight Glued Strip	1M (CS)	A201259
1 1/2"	Chisel	Medium	Galv	Plain	Straight Glued Strip	0.8M (CS)	A201509
2"	Chisel	Medium	Galv	Plain	Straight Glued Strip	0.8M (CS)	A202009
5/8" - 1 1/4"	Chisel	Medium	Galv	Plain	Straight Glued Strip	1.2M (CS)	A209809
1" - 2"	Chisel	Medium	Galv	Plain	Straight Glued Strip	1.2M (CS)	A209909
1"	Chisel	Medium	Stainless	Plain	Straight Glued Strip	1M (CS)	AX13EGAR
1 1/4"	Chisel	Medium	Stainless	Plain	Straight Glued Strip	1M (CS)	AX15EGAR
1 1/2"	Chisel	Medium	Stainless	Plain	Straight Glued Strip	1M (CS)	AX17EGAR
2"	Chisel	Medium	Stainless	Plain	Straight Glued Strip	1M (CS)	AX21EGAR

CS-Clamshell

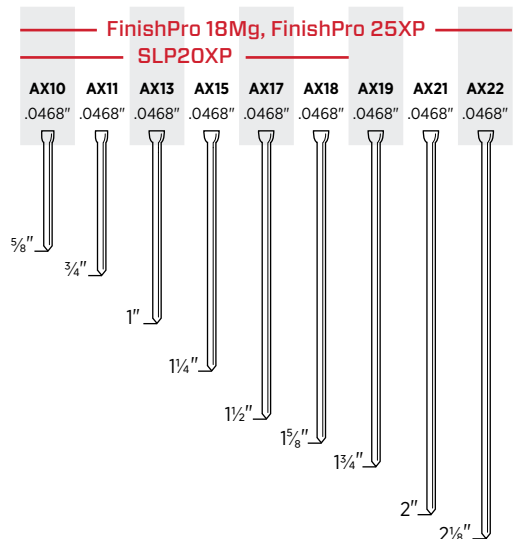

18^{GA}

Headless and Slight-Head Brad Nails

Cabinets, decorative trim, picture frames and ornamentals

Length	Point	Head	Finish	Coating	Collation	Box Count	Item Code
½"	Chisel	Headless	Galv	Plain	Straight Glued Strip	5M	AZ08EAA
¾"	Chisel	Headless	Galv	Plain	Straight Glued Strip	5M	AZ11EAA
1"	Chisel	Headless	Galv	Plain	Straight Glued Strip	5M	AZ13EAA
⅝"	Chisel	Slight	Galv	Plain	Straight Glued Strip	5M	AY10EAA
¾"	Chisel	Slight	Galv	Plain	Straight Glued Strip	5M	AY11EAA
1"	Chisel	Slight	Galv	Plain	Straight Glued Strip	5M	AY13EAA

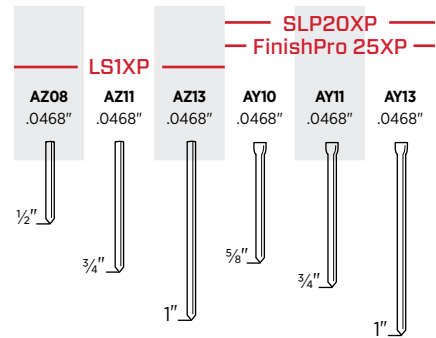

16^{GA}
20°

Angled-Strip Finish Nails*

Furniture and cabinets, molding and trim, baseboard, chair rails, window casings and upholstery trim panels

Length	Point	Head	Finish	Coating	Collation	Box Count	Item Code
1¼"	Chisel	T-head	Galv	Plain	20° Angled Glued Strip	2M (PT)	RH15EAA
1½"	Chisel	T-head	Galv	Plain	20° Angled Glued Strip	2M (PT)	RH17EAA
1¾"	Chisel	T-head	Galv	Plain	20° Angled Glued Strip	2M (PT)	RH19EAA
2"	Chisel	T-head	Galv	Plain	20° Angled Glued Strip	2M (PT)	RH21EAA
2½"	Chisel	T-head	Galv	Plain	20° Angled Glued Strip	2M (PT)	RH25EAA

PT-Plastic Tub

*NOTE: ONLY Fits 16 Gauge/20° Finish Nailers

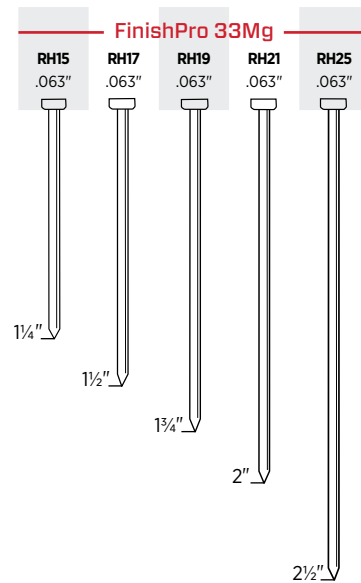

16^{GA}

Straight-Strip Finish Nails

Furniture and cabinets, molding and trim, baseboard, chair rails, window casings and upholstery trim panels

Length	Point	Head	Finish	Coating	Collation	Box Count	Item Code
¾"	Chisel	T-head	Galv	Plain	Straight Glued Strip	2M	M001000
1"	Chisel	T-head	Galv	Plain	Straight Glued Strip	2M (PT)	M001001
1¼"	Chisel	T-head	Galv	Plain	Straight Glued Strip	2M (PT)	M001002
1½"	Chisel	T-head	Galv	Plain	Straight Glued Strip	2M (PT)	M001003
1¾"	Chisel	T-head	Galv	Plain	Straight Glued Strip	2M (PT)	M001004
2"	Chisel	T-head	Galv	Plain	Straight Glued Strip	2M (PT)	M001005
2½"	Chisel	T-head	Galv	Plain	Straight Glued Strip	2M (PT)	M001007
1"	Chisel	T-head	Galv	Plain	Straight Glued Strip	1.2M (CS)	A401009
1¼"	Chisel	T-head	Galv	Plain	Straight Glued Strip	1.2M (CS)	A401259
1½"	Chisel	T-head	Galv	Plain	Straight Glued Strip	0.7M (CS)	A401509
1¾"	Chisel	T-head	Galv	Plain	Straight Glued Strip	0.7M (CS)	A401759
2"	Chisel	T-head	Galv	Plain	Straight Glued Strip	0.7M (CS)	A402009
2½"	Chisel	T-head	Galv	Plain	Straight Glued Strip	0.7M (CS)	A402509
1¼" - 2½"	Chisel	T-head	Galv	Plain	Straight Glued Strip	0.8M (CS)	A409809
1½"	Chisel	T-head	Stainless	Plain	Straight Glued Strip	0.7M	M001003GR
2"	Chisel	T-head	Stainless	Plain	Straight Glued Strip	0.7M	M001005GR
2½"	Chisel	T-head	Stainless	Plain	Straight Glued Strip	0.7M	M001007GR

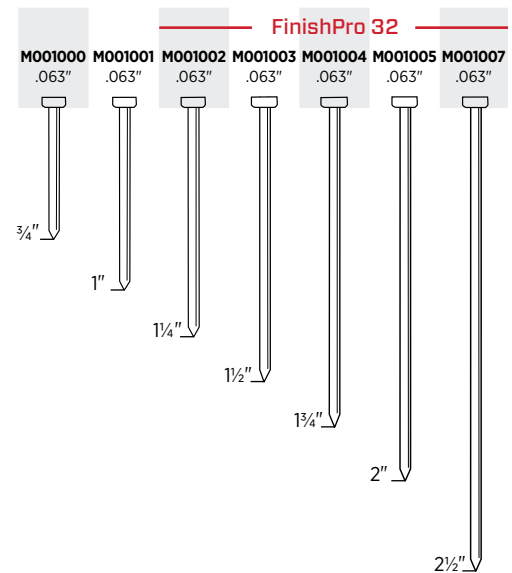

CS-Clamshell, PT-Plastic Tub

15^{GA}
34°

Angled-Strip Finish Nails

Furniture and cabinets, molding and trim, baseboard, chair rails, doors and window casings

Length	Point	Head	Finish	Coating	Collation	Box Count	Item Code
1"	Chisel	Brad	Bright	Sencote	34° Angled Taped Strip	4M	DA13EPBN
1¼"	Chisel	Brad	Bright	Sencote	34° Angled Taped Strip	4M	DA15EPBN
1½"	Chisel	Brad	Bright	Sencote	34° Angled Taped Strip	4M	DA17EPBN
1¾"	Chisel	Brad	Bright	Sencote	34° Angled Taped Strip	4M	DA19EPBN
2"	Chisel	Brad	Bright	Sencote	34° Angled Taped Strip	4M	DA21EPBN
2¼"	Chisel	Brad	Bright	Sencote	34° Angled Taped Strip	4M	DA23EPBN
2½"	Chisel	Brad	Bright	Sencote	34° Angled Taped Strip	3M	DA25EPB
1½"	Chisel	Brad	Bright	Sencote	34° Angled Taped Strip	0.7M (CS)	A301500
1¾"	Chisel	Brad	Bright	Sencote	34° Angled Taped Strip	0.7M (CS)	A301750
2"	Chisel	Brad	Bright	Sencote	34° Angled Taped Strip	0.7M (CS)	A302000
2½"	Chisel	Brad	Bright	Sencote	34° Angled Taped Strip	0.7M (CS)	A302500
1¼"	Chisel	Brad	Galv	Sencote	34° Angled Taped Strip	4M	DA15EABN
1½"	Chisel	Brad	Galv	Sencote	34° Angled Taped Strip	4M	DA17EABN
1¾"	Chisel	Brad	Galv	Sencote	34° Angled Taped Strip	4M	DA19EABN
2"	Chisel	Brad	Galv	Sencote	34° Angled Taped Strip	4M	DA21EABN
2½"	Chisel	Brad	Galv	Sencote	34° Angled Taped Strip	3M	DA25EAB
2"	Chisel	Brad	Galv	Sencote	34° Angled Taped Strip	0.7M (CS)	A302009
2½"	Chisel	Brad	Galv	Sencote	34° Angled Taped Strip	0.7M (CS)	A302509
2"	Chisel	Brad	Stainless	Plain	34° Angled Taped Strip	2M	DA21EGBN
2½"	Chisel	Brad	Stainless	Plain	34° Angled Taped Strip	1.2M	DA25EGB
1¼"	Diamond	Brad	Hardened*	Plain	34° Angled Taped Strip	4M	DA15AIA
1½"	Diamond	Brad	Hardened*	Plain	34° Angled Taped Strip	4M	DA17AIA
1¾"	Diamond	Brad	Hardened*	Plain	34° Angled Taped Strip	4M	DA19AIA

CS-Clamshell

*Hardened regular galvanized heat treated 15 Gauge for steel stud and trim application

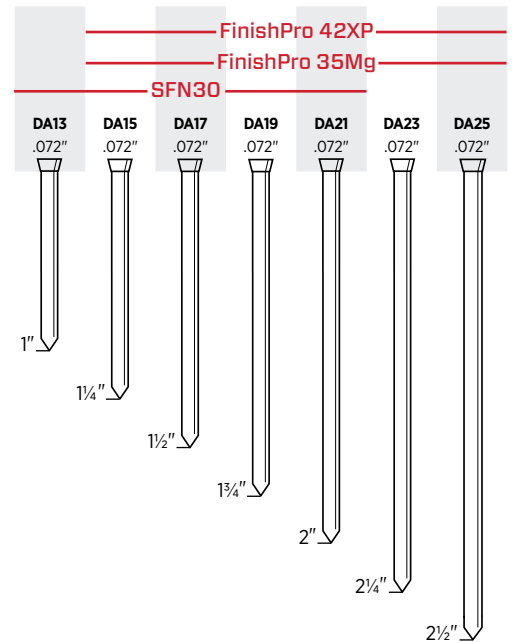

The Best Finish Nails in the Business.

SENCO® has the finish nails to meet all your finish and trim needs. In addition to offering a wide variety of fastener ranges and gauges, we also offer a full line of tools that drive them.



FINISH & WOODWORKING FASTENERS

19^{GA} 1/4" Crown Medium Wire Staples

Cabinets, drawers, soffits, lattice, casebacks						
Length	Point	Finish	Coating	Collation	Box Count	Item Code
1/2"	Chisel	Galv	Sencote	Glued	10M	K08BABN
5/8"	Chisel	Galv	Sencote	Glued	10M	K10BABN
3/4"	Chisel	Galv	Sencote	Glued	10M	K11BAB
7/8"	Chisel	Galv	Sencote	Glued	5M	K12BAB
1"	Chisel	Galv	Sencote	Glued	5M	K13BABN

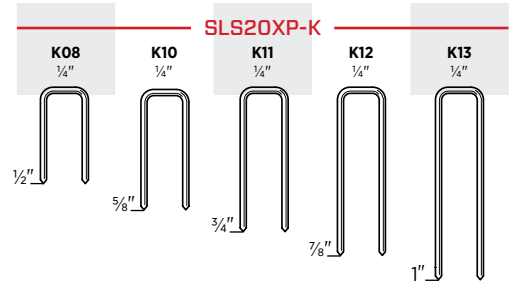

19^{GA} 3/16" Crown Medium Wire Staples

Cabinets, drawers, lattice, laminated hardwood flooring						
Length	Point	Finish	Coating	Collation	Box Count	Item Code
1/2"	Blunt	Galv	Sencote	Glued	5M	R08BAB
5/8"	Blunt	Galv	Sencote	Glued	5M	R10BAB
3/4"	Blunt	Galv	Sencote	Glued	5M	R11BAB
1"	Blunt	Galv	Sencote	Glued	5M	R13BAB

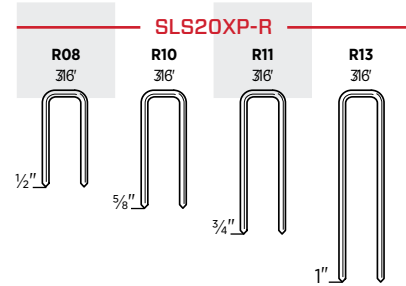

18^{GA} 1/4" Crown Medium Wire Staples

Cabinets, casebacks, drawers, upholstery, soffits, underlayment, lattice & insulation sheathing						
Length	Point	Finish	Coating	Collation	Box Count	Item Code
3/4"	Chisel	Bright	Sencote	Glued	5M	L11BRB
1"	Chisel	Bright	Sencote	Glued	5M	L13BRBN
1"	Chisel	Bright	Sencote	Glued	40M	L13BRBP
1 1/8"	Chisel	Bright	Sencote	Glued	5M	L14BRB
1 1/4"	Chisel	Bright	Sencote	Glued	5M	L15BRB
3/8"	Chisel	Galv	Sencote	Glued	10M	L06BAB
7/16"	Chisel	Galv	Sencote	Glued	24M	L07BABP
7/16"	Chisel	Galv	Sencote	Glued	24M	L07QBPP
1/2"	Chisel	Galv	Sencote	Glued	5M	L08BABN
1/2"	Chisel	Galv	Sencote	Glued	10M	L08BAB
5/8"	Chisel	Galv	Sencote	Glued	5M	L10BABN
5/8"	Cross Cut	Galv	Sencote	Glued	5M	L10HABN
3/4"	Chisel	Galv	Sencote	Glued	5M	L11BAB
3/4"	Cross Cut	Galv ¹	Sencote	Glued	5M	L11HBB
3/4"	Cross Cut	Galv	Sencote	Glued	5M	L11HAB
7/8"	Chisel	Galv	Sencote	Glued	5M	L12BAB
7/8"	Chisel	Galv	Sencote	Glued	5M	L12QBQ
1"	Chisel	Galv	Sencote	Glued	5M	L13BABN
1"	Cross Cut	Galv	Sencote	Glued	5M	L13HABN
1 1/8"	Chisel	Galv	Sencote	Glued	5M	L14BAB
1 1/4"	Chisel	Galv	Sencote	Glued	5M	L15BAB
1 1/2"	Chisel	Galv	Sencote	Glued	5M	L17BAB
5/8"	Chisel	Galv	Sencote	Glued	1.2M (CS)	A800629
3/4"	Chisel	Galv	Sencote	Glued	.9M (CS)	A800759
1"	Chisel	Galv	Sencote	Glued	.9M (CS)	A801009
1 1/4"	Chisel	Galv	Sencote	Glued	.7M (CS)	A801259
1/2"	Chisel	Galv	Sencote	Glued	.6M (CS)	A801509
1/2" - 1 1/2"	Chisel	Galv	Sencote	Glued	.9M (CS)	A809909
5/8"	Chisel	Stainless ²	Plain	Glued	5M	L10BHA
3/4"	Chisel	Stainless	Plain	Glued	5M	L11BGA
1 1/8"	Chisel	Stainless	Plain	Glued	5M	L14BGA

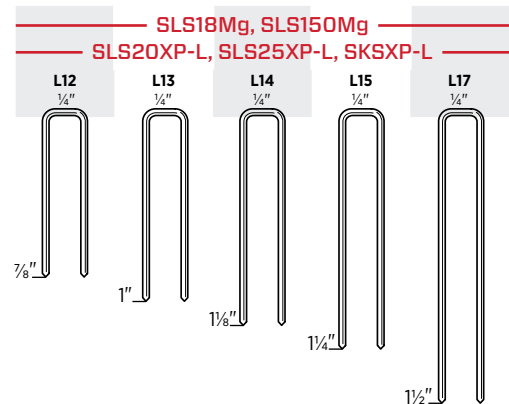
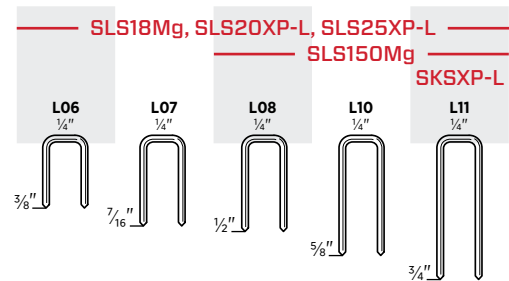

¹ Galvanized High Tensile, ² Stainless Steel High Tensile AISI-304
CS-Clamshell

18^{GA} 3/8" Crown Medium Wire Staples

Cabinets, casebacks, drawers, upholstery, soffits, underlayment, lattice and sheathing

Length	Point	Finish	Coating	Collation	Box Count	Item Code
5/8"	Chisel	Bright	Sencote	Glued	5M	M10BRBN
3/4"	Chisel	Bright	Sencote	Glued	5M	M11BRBN
1"	Chisel	Bright	Sencote	Glued	5M	M13BRB
3/8"	Chisel	Galv	Sencote	Glued	10M	M06BABN
1/2"	Chisel	Galv	Sencote	Glued	10M	M08BAB
5/8"	Chisel	Galv	Sencote	Glued	5M	M10BABN
3/4"	Chisel	Galv	Sencote	Glued	5M	M11BABN
7/8"	Chisel	Galv	Sencote	Glued	5M	M12BAB
1"	Chisel	Galv	Sencote	Glued	5M	M13BAB
1 1/4"	Chisel	Galv	Sencote	Glued	10M	M15BAB
1 1/2"	Chisel	Galv	Sencote	Glued	10M	M17BAB

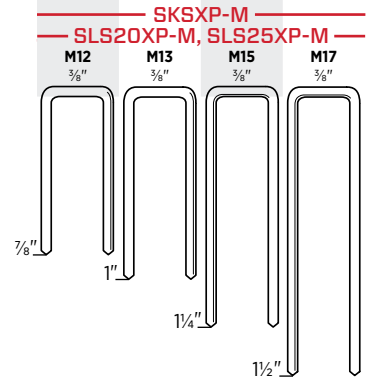
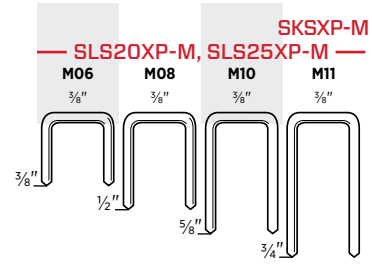

16^{GA} 7/16" Crown Heavy Wire Staples

Cabinets, casebacks, drawers, upholstery, soffits, underlayment, lattice and sheathing

Length	Point	Finish	Coating	Collation	Box Count	Item Code
3/4"	Chisel	Bright	Sencote	Glued	5M	N11BRB
1"	Chisel	Bright	Sencote	Glued	5M	N13BRB
1 1/8"	Chisel	Bright	Sencote	Tape	10M	N14BRB
1 1/4"	Chisel	Bright	Sencote	Tape	10M	N15BRB
1 3/8"	Chisel	Bright	Sencote	Tape	10M	N16BRB
1 3/8"	Step	Bright	Sencote	Tape	10M	N16RRB
1 1/2"	Chisel	Bright	Sencote	Tape	10M	N17BRB
1 5/8"	Chisel	Bright	Sencote	Tape	10M	N18BRB
1 3/4"	Chisel	Bright	Sencote	Tape	10M	N19BRB
2"	Chisel	Bright	Sencote	Tape	10M	N21BRB
1/2"	Chisel	Galv	Sencote	Tape	5M	N08BABN
1/2"	Chisel	Galv*	Sencote	Glued	5M	N08BBBN
1/2"	Diverg	Galv*	Sencote	Glued	5M	N08FBB
5/8"	Chisel	Galv	Sencote	Glued	5M	N10BAB
3/4"	Chisel	Galv	Sencote	Glued	5M	N11BAB
3/4"	Diverg	Galv*	Sencote	Glued	5M	N11FBB
7/8"	Chisel	Galv	Sencote	Glued	5M	N12BABN
7/8"	Diverg	Galv	Sencote	Glued	5M	N12FABN
1"	Chisel	Galv	Sencote	Glued	5M	N13BAB
1"	Diverg	Galv	Sencote	Glued	5M	N13FAB
1 1/8"	Chisel	Galv	Sencote	Tape	10M	N14BAB
1 1/8"	Diverg	Galv	Sencote	Glued	10M	N14FAB
1 1/4"	Chisel	Galv	Sencote	Tape	10M	N15BAB
1 1/4"	Diverg	Galv	Sencote	Glued	10M	N15FAB
1 3/8"	Chisel	Galv	Sencote	Tape	10M	N16BAB
1 1/2"	Chisel	Galv	Sencote	Tape	10M	N17BAB
1 1/2"	Chisel	Galv	Sencote	Glued	10M	N17BPE
1 5/8"	Chisel	Galv	Sencote	Tape	10M	N18BAB
1 3/4"	Chisel	Galv	Sencote	Tape	10M	N19BAB
1 3/4"	Chisel	Galv	Sencote	Glued	10M	N19BPE
2"	Chisel	Galv	Sencote	Tape	10M	N21BAB
2"	Chisel	Galv	Sencote	Glued	10M	N21BPE
1 1/4"	Chisel	Stainless	Sencote	Glued	3M	N15BGB
1 1/2"	Chisel	Stainless	Sencote	Glued	3M	N17BGB
1 3/4"	Chisel	Stainless	Sencote	Glued	3M	N19BGBN
2"	Chisel	Stainless	Sencote	Glued	3M	N21BGBN

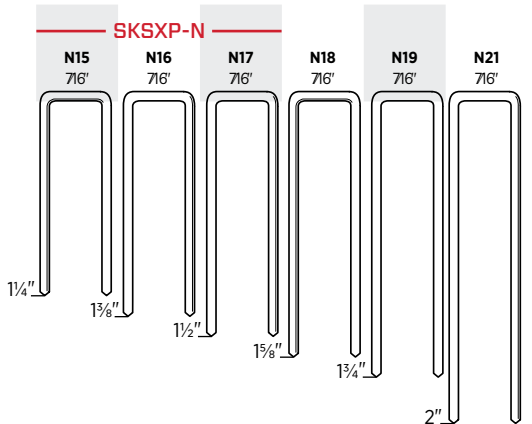
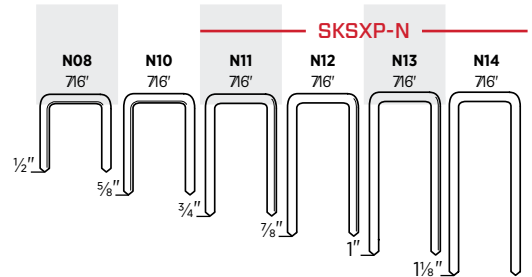

*Galvanized High Tensile

25^{GA} Sencor® 1" Crown Corrugated Fastener

Butt and miter joints						
Length	Point	Finish	Coating	Collation	Box Count	Item Code
¼"	Sharp Chisel	Bright	Plain	Glued	8M	X04NRA
⅜"	Sharp Chisel	Bright	Plain	Glued	5M	X06NRA
½"	Sharp Chisel	Bright	Plain	Glued	4M	X08NRA

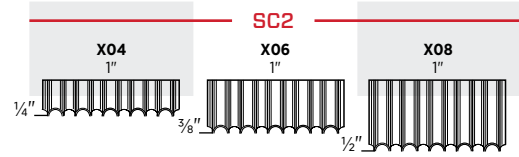

SENCOR® CORRUGATED-FASTENERS

SENCOR corrugated fasteners provide twice the joint strength of ordinary fasteners. Available in 1" crown and 3 lengths ¼", ⅜" & ½" to ensure maximum joint strength. Use this fastener for butt & miter joints, truss construction, wooden boxes, pallet repair, cabinet and furniture frames.



25^{GA} Senclamp® 7/16" Crown Joint Fastener

Butt and miter joints						
Length	Point	Finish	Coating	Collation	Box Count	Item Code
⅝"	Chisel	Bright	Plain	Glued and Taped	3M	Y05BFA
7/16"	Chisel	Bright	Plain	Glued and Taped	3M	Y07BFA
9/16"	Chisel	Bright	Plain	Glued and Taped	3M	Y09BFAN

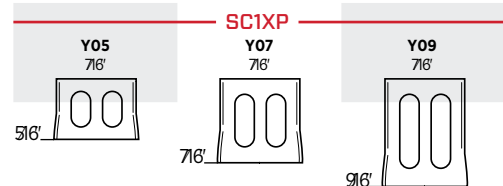

SENCLAMP® JOINT-FASTENERS

SENCLAMP has a special webbed design that draws the material together as it drives through it. Made from carbon steel, fasteners are available in 7/16" crown and 3 lengths ⅝", 7/16" & 9/16" to best suit your requirements. Designed for a wide range of joint fastening applications, Senclamp secures them better, faster and for less.

FRAMING, SHEATHING & SUBFLOOR

NAILING THE RIGHT BALANCE OF SIZE, WEIGHT AND POWER

We offer a wide selection of strip and coil framing and sheathing nailers, including the award winning FramePro®325XP.

- Compact to maneuver around wall studs and floor joists easily
- Lightweight and ergonomic to reduce fatigue
- Built tough and powerful enough to drive fasteners into the most demanding substrates

APPLICATIONS

Framing, sheathing, truss building, installing subflooring, decking or fencing, assembling boxes or making pallets

FEATURES

- Low profile designs allow for easy access between studs and joists
- Highly efficient internal design for increased durability and less wear and tear on the compressor
- Dry fire lock-out prevents dry firing and signals user when to reload
- Aggressive contact element for precise toe nailing



FramePro®325XP

3¼" PAPER TAPED FRAMING NAILER

ITEM# 4Z0101N

34°



Features

- Patented TrueDrive magazine reduces jams and mis-feeds
- Efficient internal design, means less wear and tear on the compressor
- Aggressive toenail safety
- Fits easily between studs and joists

FramePro®701XP

3½" PAPER TAPED FRAMING NAILER

ITEM# 2H0133N

34°



Features

- Straight-line 34° magazine for better line of sight
- Simple two-step loading
- Aggressive toenail safety
- Fits easily between studs and joists

SN951XP

4" PAPER TAPED FRAMING NAILER

ITEM# 5B0001N

34°



Features

- Patented TrueDrive magazine — reduces jams and mis-feeds
- Efficient internal design, means less wear and tear on the compressor
- Aggressive toenail safety
- Fits easily between studs and joists

PROHEAD® TECHNOLOGY

SENCO's offset full round-head nail.

Design allows round ProHead® nails to be collated in a nested shank-to-shank 34° strip.



- Superior holding power.
- Fewer partial drives.
- Fewer pull-outs.
- Superior strip integrity.
- Proudly manufactured in Cincinnati, Ohio.



Product Reference Chart

TOOL SPECS	FramePro®325XP	FramePro®701XP	SN951XP
Trigger	Selectable	Sequential	Selectable
Op. Pressure	70-120 psi (4.8-8.3 bar)	70 - 120 psi (4.8-8.3 bar)	70-120 psi (4.8-8.3 bar)
Air Consumption (60 CPM)	5.2 scfm	10 scfm	7.9 scfm
Air Inlet	¾" NPT	¾" NPT	¾" NPT
Weight	7.9 lbs (3.58 kg)	8 lbs (3.62 kg)	8.5 lbs (3.86 kg)
Height	11.9" (302 mm)	13.25" (337 mm)	13.8" (351 mm)
Length	17.3" (440 mm)	15.13" (384 mm)	17.3" (440 mm)
Width	4.5" (114 mm)	4.17" (106 mm)	4.76" (121 mm)
Main Body Material	Aluminum	Aluminum	Aluminum
Warranty	5 yrs	5 yrs	5 yrs
FASTENER SPECS	Fasteners are located on pages 37 - 45		
Capacity	83	70	83
Range	2"-3¼"	2"-3½"	2¾"-4"
Shank	.113"-.148"	.113"-.148"	.113"-.148"
Angle/Collation	34° Angled Taped Strip	34° Angled Taped Strip	34° Angled Taped Strip
Series	GC, GE, HC, HE, HF, KC ProHead G5, G6, H5, H6, K5, K6	GC, GE, HC, HE, HF, KC ProHead G5, G6, H5, H6, K5, K6	GC, GE, HC, HE, HF, KC ProHead G5, G6, H5, H6, K5, K6
TOOL FEATURES			
Tool-Free Depth-of-Drive	Yes	Yes	Yes
Rafter Hook	Yes	Yes	Yes
Dry fire lock-out	Yes	Yes	Yes

FramePro®325FRHXP 3¼" FULL ROUND-HEAD FRAMING NAILER

ITEM# 4H0101N

20°



Features

- Patented TrueDrive magazine reduces jams and mis-feeds
- Effective internal design means less wear and tear on the compressor
- Aggressive toenail safety
- Fits easily between studs and joists

FramePro®752XP 3½" FULL ROUND-HEAD FRAMING NAILER

ITEM# 2F0103N

20°



Features

- 20° in-line magazine provides excellent maneuverability and line of sight
- Simple two-step loading
- Aggressive toenail safety
- Fits easily between studs and joists

FramePro®702XP

3½" FULL ROUND HEAD FRAMING NAILER

ITEM# 2K0103N

20°

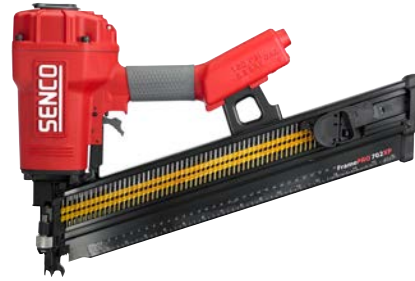

Features

- 20° in-line magazine provides excellent maneuverability and line of sight
- Simple two-step loading
- Aggressive toenail safety
- Fits easily between studs and joists

SN952XP

3½" FULL ROUND-HEAD FRAMING NAILER

ITEM# 5A0001N

20°



Features

- Patented TrueDrive magazine reduces jams and mis-feeds
- Effective internal design means less wear and tear on the compressor
- Aggressive toenail safety
- Fits easily between studs and joists

Product Reference Chart

TOOL SPECS	FramePro®325FRHX	FramePro®702XP	FramePro®752XP	SN952XP
Trigger	Selectable	Sequential	Sequential	Selectable
Op. Pressure	70-120 psi (4.8-8.3 bar)	70-120 psi (4.8-8.3 bar)	70-120 psi (4.8-8.3 bar) 11	70-120 psi (4.8-8.3 bar)
Air Consumption (60 CPM)	5.2 scfm	10 scfm	scfm	7.9 scfm
Air Inlet	¾" NPT	¾" NPT	¾" NPT	¾" NPT
Weight	7.9 lbs (3.58 kg)	8.4 lbs (3.8 kg)	8.7 lbs (3.97 kg)	8.4 lbs (3.8 kg)
Height	11.9" (302 mm)	13.25" (337 mm)	14.25" (362 mm)	13.57" (345 mm)
Length	17.3" (440 mm)	20" (508 mm)	20" (508 mm)	20.3" (516 mm)
Width	4.5" (114 mm)	4.17" (106 mm)	4.17" (106 mm)	4.75" (121 mm)
Main Body Material	Aluminum	Aluminum	Aluminum	Aluminum
Warranty	5 yrs	5 yrs	5 yrs	5 yrs
FASTENER SPECS	Fasteners are located on pages 37 - 45			
Capacity	64	60	60	64
Range	2"-3¼"	2"-3½"	2"-3½"	2½"-3½"
Shank	.113"-.148"	.113"-.148"	.113"-.162"	.120"-.162"
Angle/Collation	20° Angled Plastic Strip	20° Angled Plastic Glued Strip	20° Angled Plastic Strip	20° Angled Plastic Strip
Series	GD, GL, HD, HL, KD, MD	GD, GL, HD, HL, KD, MD	GD, GL, HD, HL, KD, MD	GD, GL, HD, HL, KD, MD
TOOL FEATURES				
Tool-Free Depth-of-Drive	Yes	Yes	Yes	Yes
Rafter Hook	Yes	Yes	Yes	Yes
Dry Fire Lock-Out	Yes	Yes	Yes	Yes

SCN60XP

2¾" COIL NAILER

ITEM# 520101N

15°



Features

- High load capacity
- EZ load design saves time
- Fast cycle time increases productivity
- Light and fast for greater productivity

SCN65XP

3½" COIL NAILER

ITEM# 540101N - FLAT SAFETY; 540104N - TOENAIL SAFETY

15°



Features

- High load capacity
- EZ load design saves time
- Fast cycle time increases productivity
- Light and fast for greater productivity

SCN63LDXP

2½" COIL NAILER (SPECIAL ORDER TOOL)

ITEM# 8W0001N

15°



Features

- Patent pending design specifically for structural foam insulation.
- Long drive blade ensures proper nail set
- EZ load design saves time
- Safety guide foot for accurate nail placement

SCN49XP

2½" COIL NAILER

ITEM# 5J0001N

15°



Features

- Well balanced and lightweight
- Dual collation allows choice between wire or plastic collation
- High load capacity

Product Reference Chart

TOOL SPECS	SCN60XP	SCN65XP	SCN63LDXP	SCN49XP
Trigger	Contact	Contact	Sequential	Selectable
Op. Pressure	70-120 psi (4.8-8.3 bar)	70-120 psi (4.8-8.3 bar)	70- 20 psi (4.8-8.3 bar)	70 - 120 psi (4.8-8.3 bar)
Air Consumption (60 CPM)	8.29 scfm	9.54 scfm	9.54 scfm	3.9 scfm
Air Inlet	¾" NPT	¾" NPT	¾" NPT	¾" NPT
Weight	7.5 lbs (3.4 kg)	8 lbs (3.6 kg)	8.1 lbs (3.67 kg)	5.1 lbs (2.31 kg)
Height	12.38" (314 mm)	14.1" (359 mm)	13.35" (339 mm)	12" (304 mm)
Length	12.88" (327 mm)	12.88" (327 mm)	12.88" (327 mm)	12.25" (314 mm)
Width	5.38" (137 mm)	5.38" (137 mm)	5.38" (137 mm)	5.19" (132 mm)
Main Body Material	Aluminum	Aluminum	Aluminum	Magnesium
Warranty	5 yrs	5 yrs	5 yrs	5 yrs
FASTENER SPECS	Fasteners are located on pages 37 - 45			
Capacity	250-275	225-275	225-250	250-375
Range	2"-2¾"	2"-3½"	2¾"-2½"	1¼"-212"
Shank	.099 - .113"	.099"-.131"	.113"-.131"	.082"-.113"
Angle/Collation	Flat, 15° Angled Coil Wire	Flat, 15° Angled Coil Wire	Flat, 15° Angled Coil Wire	15° Angled Flat Wire Coil or Plastic Carrier Strip BE, BK, BL, BT, ED, EL, GD, GL, SE
Series	BK, BL, BT, GD, GL, HR	BJ, BK, BL, BT, GD, GL, HD, HK, HL, KD	GD, GL, KD	
TOOL FEATURES				
Tool-Free Depth-of-Drive	Yes	Yes	Yes	Yes
Rafter Hook	No	No	No	—
Dry Fire Lock-Out	No	No	No	—

JoistPro™150XP

1½" METAL CONNECTOR NAILER

ITEM# 7L0001N

34°



Features

- Patent-pending nosepiece leads with nail tip for accurate placement
- Powerful enough to drive through engineered lumber
- Lightweight and well-balanced

JoistPro™250XP

1½" - 2½" METAL CONNECTOR NAILER

ITEM# 6K0001N

34°



Features

- Nosepiece probe locates metal connector holes, providing accurate nail placement
- Powerful enough to drive through engineered lumber
- Lightweight and well-balanced

Mini Hand Nailer

2" - 3½" BULK NAILER

ITEM# PC1195



Features

- Compact and powerful enough to drive 2" - 3½" bulk nails
- Magnetic nose holds nail in place for safe, accurate placement
- Ultra-light at just 1 pound

A20 Hand Nailer

2" - 7" BULK NAILER

ITEM# PC0781



Features

- Drives bulk nails from 2" to 7"
- Soft rubber palm pad for comfortable grip
- Magnetic nose holds nail in place for safe, accurate placement
- Includes leather strap for comfort

Product Reference Chart

TOOL SPECS	JoistPro™150XP	JoistPro™250XP	Mini Hand Nailer	A20 Hand Nailer
Trigger	Sequential	Sequential	—	—
Op. Pressure	70-120 psi (4.8-8.3 bar)	70-120 psi (4.8-8.3 bar)	60-10 psi (4-7.6 bar) 2 -	50-125 psi (3.5-8.4 bar)
Air Consumption (60 CPM)	2.3 scfm	4.1 scfm	4 scfm	2-4 scfm
Air Inlet	¼" NPT	¼" NPT	¼" NPT	⅜" NPT
Weight	4.6 lbs (2.08 kg)	5.9 lbs (2.68 kg)	1 lb (.45 kg)	2.4 lbs (1.1 kg)
Height	11.97" (302 mm)	14.1" (359 mm)	4" (101 mm)	5.8" (122 mm)
Length	10.35" (263 mm)	13.8" (350 mm)	2.75" (70 mm)	4" (101 mm)
Width	4.0" (100 mm)	4.3" (110 mm)	2" (55.6 mm)	3.25" (83 mm)
Main Body Material	Magnesium	Magnesium	Aluminum	Aluminum
Warranty	5 yrs	5 yrs	1 yr	1 yr
FASTENER SPECS	Fasteners are located on pages 37 - 45			
Capacity	30	20	1	1
Range	1½"	1½" - 2½"	Bulk nails from 2" - 3½"	Bulk nails from 2" - 3½" up to 7" w/opt. guide tips .113"-.148"
Shank	.131"-.148"	.131"-.162"	—	—
Angle/Collation	34° Paper Tape Strip	34° Paper Tape Strip	—	—
Series	KJ, MD	KJ, MD, ND	—	—
TOOL FEATURES				
Tool-Free Depth-of-Drive	No	No	—	—
Rafter Hook	Yes	Yes	—	—
Dry Fire Lock-Out	Yes	Yes	—	—

SCP40XP

1½" STANDARD PRESSURE PNEUMATIC CONCRETE & STEEL PINNER

ITEM# 7J0001N

20°



Features

- 10 times faster than powder-actuated systems
- No licensing required to operate
- Works with conventional air compressors, hoses and fittings
- Operates at extreme temperatures and altitudes

Concrete Pinner

Plaster, stucco and building wrap fastening attachment

	Fits Tools	Range	Item #	
SENCO	SCP40XP	1¼"	NPC035	 Magnetic washer nose piece

Galvanized Metal Washer

Item #	Diameter	Box Count	Fits SCP40XP, GT40CP
SWM125B	1¼"	1M	.109" Dia. Concrete Pins

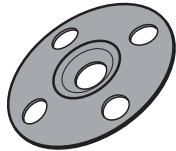

WC150XP

1" WIDE CROWN, 1½" HEAVY WIRE STAPLER

ITEM# 4W0001N

16_{GA}



Features

- Robust firing valve design makes the tool fast, powerful and easy to maintain
- High-strength composite magazine and metal magazine guide prevents wear
- Positive-locking adjustable depth-of-drive ensures consistently flush drives
- EZ-Clear™ latch virtually eliminates downtime caused by fastener jams

WC200XP

1" WIDE CROWN, 2" HEAVY WIRE STAPLER

ITEM# 4Y0001N

16_{GA}



Features

- Robust firing valve design makes the tool fast, powerful and easy to maintain
- High-strength composite magazine and metal magazine guide prevents wear
- Positive-locking adjustable depth-of-drive ensures consistently flush drives
- EZ-Clear™ latch virtually eliminates downtime caused by fastener jams

Product Reference Chart

TOOL SPECS	SCP40XP	WC150XP	WC200XP
Trigger	Selectable	Contact	Contact
Op. Pressure	80-120 psi (5.5-8.3 bar)	70-120 psi (4.8-8.3 bar)	70-120 psi (4.8-8.3 bar)
Air Consumption (60 CPM)	5.2 scfm	3.18 scfm	3.45 scfm
Air Inlet	¾" NPT	¾" NPT	¾" NPT
Weight	7.1 lbs (3.2 kg)	5 lbs (2.3 kg)	5.3 lbs (2.4 kg)
Height	12.22" (310 mm)	9" (229 mm)	10" (254 mm)
Length	18.2" (462 mm)	15.25" (387 mm)	15.25" (387 mm)
Width	4.5" (114.4 mm)	3.5" (89 mm)	3.5" (89 mm)
Main Body Material	Aluminum	Aluminum	Aluminum
Warranty	5 yrs	5 yrs	5 yrs
FASTENER SPECS	Fasteners are located on pages 37 - 45		
Capacity	42	160	160
Range	½"-1½"	⅝"-1½"	⅞"-2"
Crown	.104"-.118"	1"	1"
Gauge/Collation	Standard Washer Style	Straight Glued Strip	Straight Glued and Taped Strip
Series	W3	P	P
TOOL FEATURES			
Tool Free Depth-of-Drive	No	Yes	Yes
Belt Hook	No	Yes	Yes
Dry Fire Lock-Out	Yes	No	No

SNS41

7/16" CROWN, 2" HEAVY WIRE
STAPLER ITEM# 3L0003N

17 GA 16 GA



Features

- Durable construction, minimizes downtime and operating costs
- EZ-Clear™ latch virtually eliminates downtime caused by fastener jams
- Fast, multi-directional stitching

SNS200XP

7/16" CROWN, 2" HEAVY WIRE
STAPLER
ITEM# 7B0001N

17 GA 16 GA



Features

- 15% more powerful than all other construction staplers in its class
- Innovative magazine removal mechanism maintains a clean, narrow line of sight for precise staple placement
- 1" lip length allows access into tight corners

SQS55XP

7/16" CROWN, 2 1/2" HEAVY WIRE STAPLER
ITEM# 660101N

15 GA



Features

- Fast — up to 15 staples per second
- EZ-Clear™ latch virtually eliminates downtime caused by fastener jams
- Rugged dependability

Product Reference Chart

TOOL SPECS	SNS41	SNS200XP	SQS55XP
Trigger	Contact	Contact	Contact
Op. Pressure	80-120 psi (5.5-8.3 bar)	70-120 psi (4.8-8.3 bar)	80-120 psi (5.5-8.3 bar)
Air Consumption (60 CPM)	5.4 scfm	6.3 scfm	6.54 scfm
Air Inlet	3/8" NPT	3/8" NPT	3/8" NPT
Weight	4.6 lbs (2.1 kg)	5.3 lbs (2.4 kg)	5.9 lbs (2.7 kg)
Height	10.75" (273 mm)	11" (279 mm)	12" (305 mm)
Length	15" (381 mm)	15" (381 mm)	14.38" (365 mm)
Width	—	3.5" (89 mm)	3.6" (92 mm)
Main Body Material	Aluminum	Aluminum	Aluminum
Warranty	5 yrs	5 yrs	5 yrs
FASTENER SPECS	Fasteners are located on pages 37 - 45		
Capacity	160	160	130
Range	1"-2"	1"-2"	1 1/4"-2 1/2"
Crown	7/16"	7/16"	7/16"
Gauge/Collation	Straight Glued and Taped Strip	Straight Glued and Taped Strip	Straight Glued and Taped Strip
Series	N, O	N, O	Q
TOOL FEATURES			
Tool-Free Depth-of-Drive	Tool required	Yes	Tool required
Belt Hook	No	Yes	No
Dry Fire Lock-Out	No	No	No

FRAMING, SHEATHING & SUBFLOOR FASTENERS

34° Smooth-Shank Paper Taped-Collated Nails

Framing, sheathing, subfloor, decks, trusses and pallets						
Length	Point	Finish	Coating	Collation	Box Count	Item Code
2¼" x .113"	Diamond	Bt. Hardened	Plain	34° Paper taped, strip	1M	GC23AHAH
2" x .113"	Diamond	Bright	Sencote	34° Paper taped, strip	2.5M	GC21APBX
2¼" x .113"	Diamond	Bright	Sencote	34° Paper taped, strip	2.5M	GC23APBX
2⅜" x .113"	Diamond	Bright	Sencote	34° Paper taped, strip	2.5M	GC24APBX
2½" x .113"	Diamond	Bright	Sencote	34° Paper taped, strip	2.5M	GC25APBX
3" x .120"	Diamond	Bright	Sencote	34° Paper taped, strip	2.5M	HC27APBX
3¼" x .120"	Diamond	Bright	Sencote	34° Paper taped, strip	2.5M	HC28APBX
3" x .131"	Diamond	Bright	Sencote	34° Paper taped, strip	2.5M	KC27APBX
3¼" x .131"	Diamond	Bright	Sencote	34° Paper taped, strip	2.5M	KC28APBX
3½" x .131"	Diamond	Bright	Sencote	34° Paper taped, strip	2.5M	KC29APBX
3½" x .135"	Diamond	Bright	Sencote	34° Paper taped, strip	2.5M	LC29APBX
4" x .131"	Diamond	Bright	Sencote	34° Paper taped, strip	2.5M	KC31APBX
2½" x .113"	Diamond	Galv	Sencote	34° Paper taped, strip	2.5M	GC25AABX
2⅜" x .113"	Diamond	Hot Dip	Sencote	34° Paper taped, strip	2.5M	GC24ASBX
3" x .120"	Diamond	Hot Dip	Sencote	34° Paper taped, strip	2.5M	HC27ASBX
3" x .131"	Diamond	Hot Dip	Sencote	34° Paper taped, strip	2.5M	KC27ASBX
3¼" x .131"	Diamond	Hot Dip	Sencote	34° Paper taped, strip	2.5M	KC28ASBX
3½" x .131"	Diamond	Hot Dip	Sencote	34° Paper taped, strip	2.5M	KC29ASBX
3" x .131"	Diamond	Stainless	Sencote	34° Paper taped, strip	1M	KC27AGBK
3¼" x .131"	Diamond	Stainless	Sencote	34° Paper taped, strip	1M	KC28AGBK

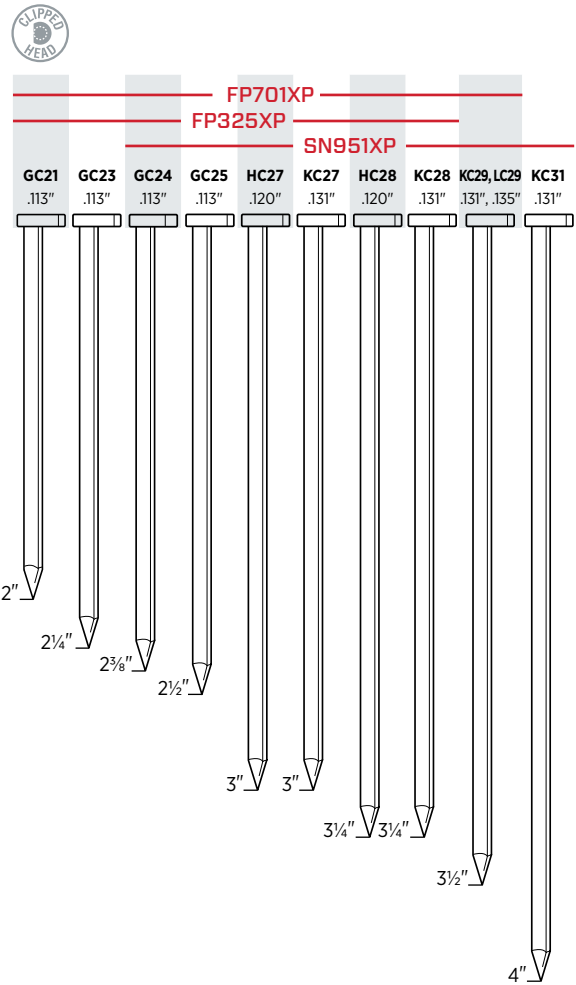

34° Ring-Shank Paper Taped-Collated Nails

Framing, sheathing, subfloor, decks, trusses and pallets						
Length	Point	Finish	Coating	Collation	Box Count	Item Code
2" x .113"	Diamond	Bright	Plain	34° Paper taped, strip	2.5M	GE21APAX
2⅜" x .113"	Diamond	Bright	Sencote	34° Paper taped, strip	2.5M	GE24APBX
2" x .113"	Diamond	Hot Dip	Sencote	34° Paper taped, strip	2.5M	GE21ASBX
2⅜" x .113"	Diamond	Hot Dip	Sencote	34° Paper taped, strip	2.5M	GE24ASBX
3" x .120"	Diamond	Hot Dip	Sencote	34° Paper taped, strip	2.5M	HE27ASBX
2⅜" x .113"	Diamond	Stainless	Sencote	34° Paper taped, strip	1M	GE24AGBX

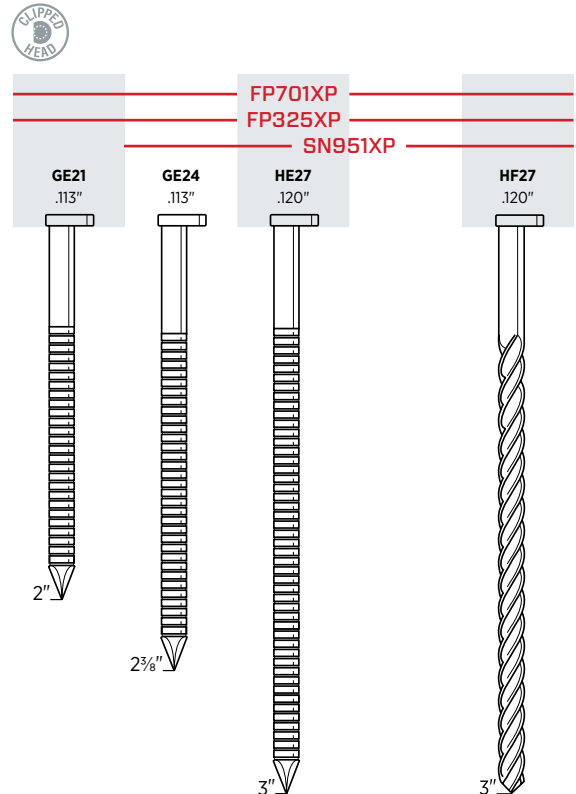

34° Screw-Shank Paper Taped-Collated Nails

Framing, sheathing, subfloor, decks, trusses and pallets						
Length	Point	Finish	Coating	Collation	Box Count	Item Code
3" x .120"	Chisel	Bright	Plain	34° Paper taped, strip	3.1M	HF27EPAX
3" x .120"	Chisel	Bright	Sencote	34° Paper taped, strip	1M	HF27EDB
3" x .120"	Diamond	Hot Dip	Sencote	34° Paper taped, strip	1M	HF27AGBK

FRAMING, SHEATHING & SUBFLOOR FASTENERS

34° ProHead® Smooth Paper-Taped Nails

Framing, sheathing, subfloor, decks, trusses and pallets						
Length	Point	Finish	Coating	Collation	Box Count	Item Code
2" x .113"	Diamond	Bright	Plain	34° Paper taped, strip	2.5M	G521APBXN
2 3/8" x .113"	Diamond	Bright	Sencote	34° Paper taped, strip	2.5M	G524APBXN
3" x .120"	Diamond	Bright	Sencote	34° Paper taped, strip	2.5M	H527APBXN
3" x .120"	Diamond	Bright	Sencote	34° Paper taped, strip	0.5M	H527APBXR
3 1/4" x .120"	Diamond	Bright	Sencote	34° Paper taped, strip	2.5M	H528APBXN
2 1/2" x .131"	Diamond	Bright	Sencote	34° Paper taped, strip	2.5M	K525APBXN
3" x .131"	Diamond	Bright	Sencote	34° Paper taped, strip	2.5M	K527APBXN
3" x .131"	Diamond	Bright	Sencote	34° Paper taped, strip	0.5M	K527APBXR
3 1/4" x .131"	Diamond	Bright	Sencote	34° Paper taped, strip	2.5M	K528APBXN
3 1/4" x .131"	Diamond	Bright	Sencote	34° Paper taped, strip	0.5M	K528APBXR
3 1/2" x .131"	Diamond	Bright	Sencote	34° Paper taped, strip	2.5M	K529APBXN
2" x .113"	Diamond	Hot Dip	Sencote	34° Paper taped, strip	2.5M	G521ASBXN
2 3/8" x .113"	Diamond	Hot Dip	Sencote	34° Paper taped, strip	2.5M	G524ASBXN
3" x .120"	Diamond	Hot Dip	Sencote	34° Paper taped, strip	2.5M	H527ASBXN
3" x .131"	Diamond	Hot Dip	Sencote	34° Paper taped, strip	2.5M	K527ASBXN
3 1/4" x .131"	Diamond	Hot Dip	Sencote	34° Paper taped, strip	2.5M	K528ASBXN
3 1/2" x .131"	Diamond	Hot Dip	Sencote	34° Paper taped, strip	2.5M	K529ASBXN

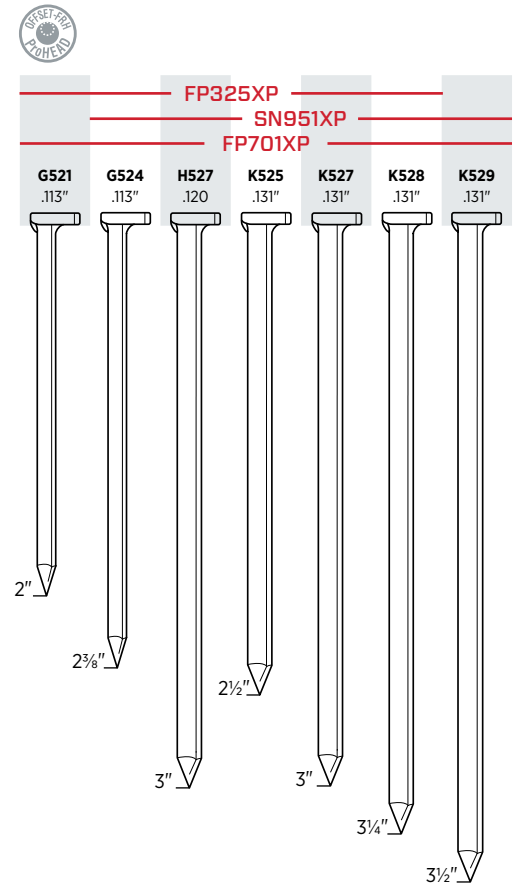

34° ProHead® Ring Paper-Taped Nails

Framing, sheathing, subfloor, decks, trusses and pallets						
Length	Point	Finish	Coating	Collation	Box Count	Item Code
2" x .113"	Diamond	Bright	Sencote	34° Paper taped, strip	2.5M	G621APBXN
2 3/8" x .113"	Diamond	Bright	Sencote	34° Paper taped, strip	2.5M	G624APBXN
3" x .120"	Diamond	Bright	Sencote	34° Paper taped, strip	2.5M	H627APBXN
3 1/4" x .131"	Diamond	Bright	Sencote	34° Paper taped, strip	2.5M	K628APBXN
2" x .113"	Diamond	Hot Dip	Sencote	34° Paper taped, strip	2.5M	G621ASBXN
2 3/8" x .113"	Diamond	Hot Dip	Sencote	34° Paper taped, strip	0.5M	G624ASBXR
2 3/8" x .113"	Diamond	Hot Dip	Sencote	34° Paper taped, strip	2.5M	G624ASBXN
3" x .120"	Diamond	Hot Dip	Sencote	34° Paper taped, strip	2.5M	H627ASBXN
3" x .120"	Diamond	Hot Dip	Sencote	34° Paper taped, strip	0.5M	H627ASBXR
3" x .131"	Diamond	Hot Dip	Sencote	34° Paper taped, strip	2.5M	K627ASBXN
3 1/4" x .131"	Diamond	Hot Dip	Sencote	34° Paper taped, strip	2.5M	K628ASBXN
3 1/2" x .131"	Diamond	Hot Dip	Sencote	34° Paper taped, strip	2.5M	K629ASBXN

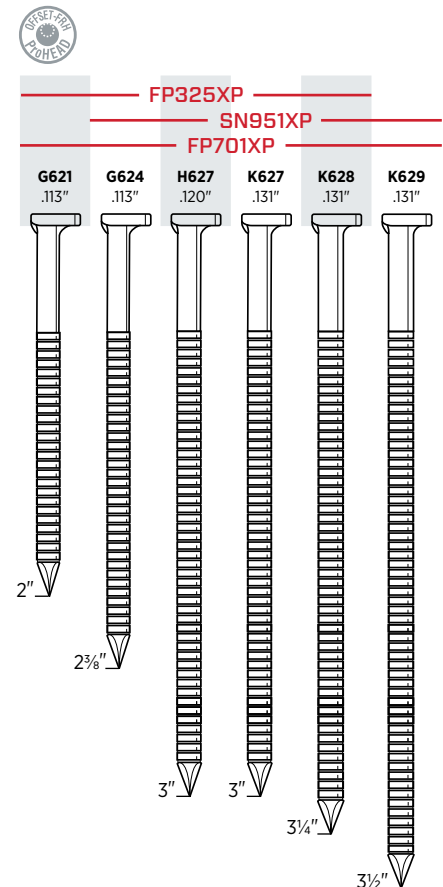

FRAMING, SHEATHING & SUBFLOOR FASTENERS

20° Smooth Shank Plastic-Collated Nails

Framing, sheathing, subfloor, decks, trusses and pallets						
Length	Point	Finish	Coating	Collation	Box Count	Item Code
2¼" x .113"	Diamond	Bt. Hardened	Plain	20° Plastic strip	2.8M	GD23AHAS
2" x .113"	Diamond	Bright	Sencote	20° Plastic strip	5M	GD21APBSN
2¼" x .148"	Diamond	Bright	Sencote	20° Plastic strip	4M	MD23APBSN
2¾" x .113"	Diamond	Bright	Sencote	20° Plastic strip	2.5M	M002038
2¾" x .113"	Diamond	Bright	Sencote	20° Plastic strip	5M	GD24APBSN
2½" x .113"	Diamond	Bright	Sencote	20° Plastic strip	5M	GD25APBSN
2½" x .131"	Diamond	Bright	Sencote	20° Plastic strip	4M	KD25APBSN
2½" x .131"	Diamond	Bright	Sencote	20° Plastic strip	2.5M	M002105
3" x .120"	Diamond	Bright	Sencote	20° Plastic strip	4M	HD27APBSN
3" x .131"	Diamond	Bright	Sencote	20° Plastic strip	4M	KD27APBSN
3" x .131"	Diamond	Bright	Sencote	20° Plastic strip	0.5M	KD27APBSR
3" x .148"	Diamond	Bright	Sencote	20° Plastic strip	4M	MD27APBSN
3¼" x .131"	Diamond	Bright	Sencote	20° Plastic strip	4M	KD28APBSN
3¼" x .131"	Diamond	Bright	Sencote	20° Plastic strip	0.5M	KD28APBSR
3¼" x .148"	Diamond	Bright	Sencote	20° Plastic strip	4M	MD28APBSN
3½" x .131"	Diamond	Bright	Sencote	20° Plastic strip	4M	KD29APBSN
3½" x .131"	Diamond	Bright	Sencote	20° Plastic strip	2.5M	M002101
2" x .113"	Diamond	Galv	Sencote	20° Plastic strip	5M	GD21AABSNS
2¾" x .113"	Diamond	Hot Dip	Sencote	20° Plastic strip	2.5M	GD24ASBS
2½" x .113"	Diamond	Galv	Sencote	20° Plastic strip	5M	GD25AABSNS
2½" x .120"	Diamond	Exterior	Sencote	20° Plastic strip	2.3M	HJ25ADBS*
2½" x .131"	Diamond	Galv	Sencote	20° Plastic strip	2.5M	KD25AABSNS
3" x .131"	Diamond	Hot Dip	Sencote	20° Plastic strip	2.5M	KD27ASBS
3" x .131"	Diamond	Galv	Sencote	20° Plastic strip	4M	KD27AABSNS
3¼" x .131"	Diamond	Hot Dip	Sencote	20° Plastic strip	2.5M	KD28ASBS
3¼" x .131"	Diamond	Galv	Sencote	20° Plastic strip	4M	KD28AABSNS
3½" x .131"	Diamond	Hot Dip	Sencote	20° Plastic strip	2.5M	KD29ASBS
3½" x .131"	Diamond	Galv	Sencote	20° Plastic strip	4M	KD29AABSNS
3¼" x .131"	Diamond	Stainless	Sencote	20° Plastic strip	1M	KD28AGBS

*Roof tile nails, drive with FramePro® 725XP or SN952XP

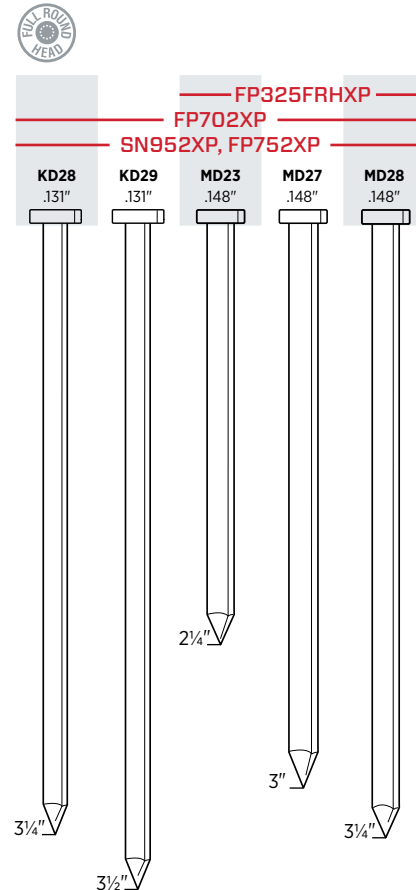
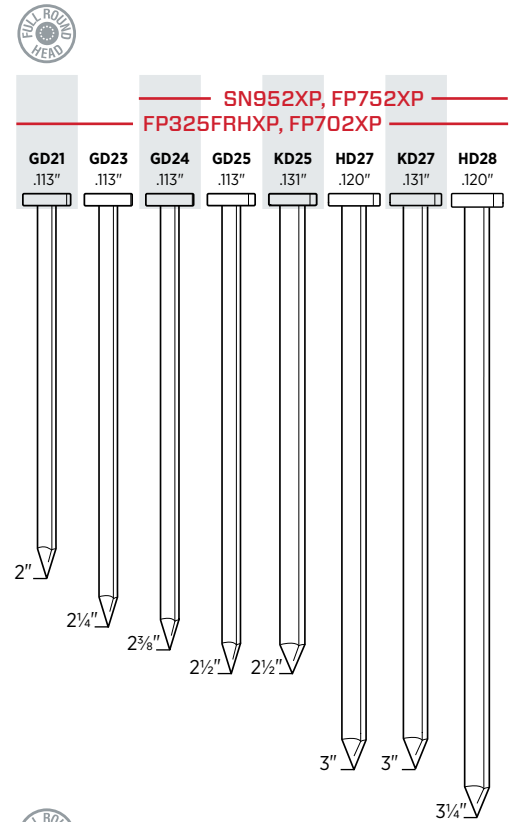

FRAMING, SHEATHING & SUBFLOOR FASTENERS

20° Ring-Shank Plastic Collated Nails

Framing, sheathing, subfloor, decks, trusses and pallets						
Length	Point	Finish	Coating	Collation	Box Count	Item Code
2 5/8" x .113"	Diamond	Hot Dip	Sencote	20° Plastic strip	0.5M	GL24ASBSR
2" x .113"	Diamond	Bright	Sencote	20° Plastic strip	5M	GL21APBSN
2 3/8" x .113"	Diamond	Bright	Sencote	20° Plastic strip	5M	GL24APBSN
2 3/8" x .113"	Diamond	Bright	Sencote	20° Plastic strip	2.5M	M002041
2" x .120"	Diamond	Hot Dip	Sencote	20° Plastic strip	2.5M	GL21ASBS
2 3/8" x .113"	Diamond	Galv	Sencote	20° Plastic strip	5M	GL24AABS
2 3/8" x .113"	Diamond	Galv	Sencote	20° Plastic strip	2.5M	M002042
2 3/8" x .113"	Diamond	Hot Dip	Sencote	20° Plastic strip	2.5M	GL24ASBS
3" x .120"	Diamond	Galv	Sencote	20° Plastic strip	4M	HL27AABS
3" x .120"	Diamond	Hot Dip	Sencote	20° Plastic strip	2.5M	HL27ASBS
2 3/8" x .113"	Diamond	Stainless	Sencote	20° Plastic strip	1M	GL24AGBS
3" x .120"	Diamond	Stainless	Sencote	20° Plastic strip	1M	HL27AGBS

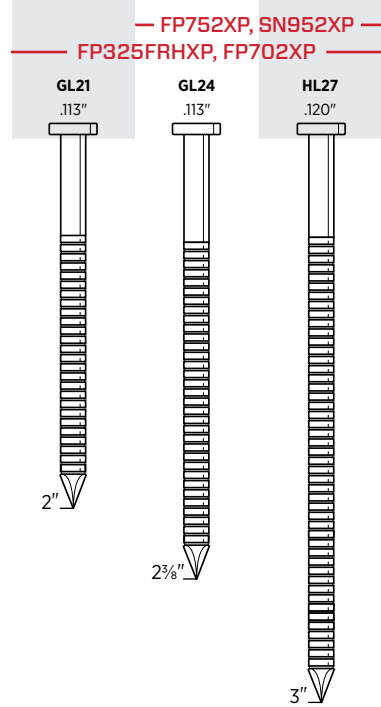

15° Ring-Shank Subflooring Nails

Superior fastening in subfloor applications							
Length	Wound/Shank	Point	Finish	Coating	Collation	Box Count	Item Code
2"	Coil, angular, flat wound	Diamond	Bright Basic	Sencote	15° Angled Coil Wire	6.6M	BT21APBF

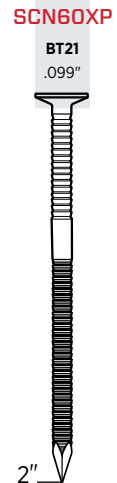

Reduce Call-backs

Eliminates pop-ups & squeaks

- Patented unique ring shank design reduces the potential of the nail backing out, addressing one of the most common flooring problems.
- The BT21APBF has been tested and proven under actual conditions.
- Reduces squeaky floors, uneven surfaces, raised fasteners, problems and call-backs.

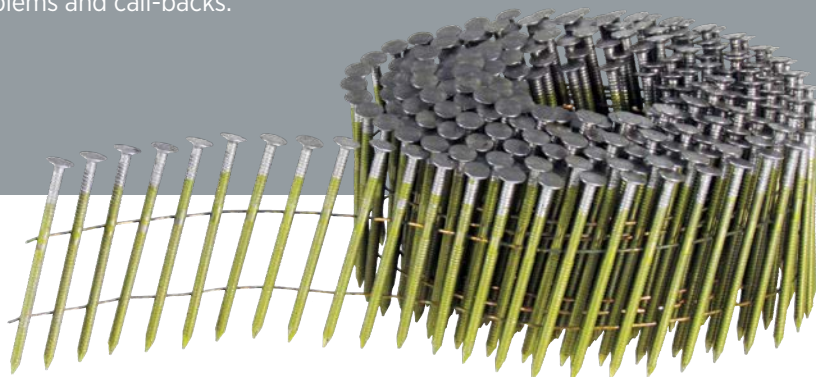

FRAMING, SHEATHING & SUBFLOOR FASTENERS

15° Smooth-Shank Coil Nails

Framing, sheathing, pallets, subfloor, decks and trusses						
Length	Point	Finish	Coating	Collation	Box Count	Item Code
2" x .113"	Diamond	Bright	Sencote	Angular, flat wire wound	6M	GD21APBF
2 3/8" x .113"	Diamond	Bright	Sencote	Angular, flat wire wound	6M	GD24APBF
2 1/2" x .113"	Diamond	Bright	Sencote	Angular, flat wire wound	6M	GD25APBF
2 1/2" x .131"	Diamond	Bright	Sencote	Angular, flat wire wound	3.6M	KD25APBF
3" x .120"	Diamond	Bright	Sencote	Angular, flat wire wound	4M	HD27APBF
3" x .131"	Diamond	Bright	Sencote	Angular, flat wire wound	3.6M	KD27APBF
3 1/4" x .120"	Diamond	Bright	Sencote	Angular, flat wire wound	4M	HD28APBF
3 1/4" x .131"	Diamond	Bright	Sencote	Angular, flat wire wound	3.6M	KD28APBF
3 1/2" x .131"	Diamond	Bright	Sencote	Angular, flat wire wound	3.6M	KD29APBF
5" x .148"	Diamond	Bright	Sencote	Angular, flat wire wound	1.8M	MD34APBF
2" x .113"	Diamond	Galv	Sencote	Angular, flat wire wound	6M	GD21AABF
2 1/2" x .113"	Diamond	Galv	Sencote	Angular, flat wire wound	6M	GD25AABF
3" x .131"	Diamond	Galv	Sencote	Angular, flat wire wound	3.6M	KD27AABF
3" x .131"	Diamond	Hot Dip	Sencote	Angular, flat wire wound	2.4M	KD27ASBF
3 1/4" x .131"	Diamond	Galv	Sencote	Angular, flat wire wound	3.6M	KD28AABF
3 1/4" x .131"	Diamond	Hot Dip	Sencote	Angular, flat wire wound	2.4M	KD28ASBF

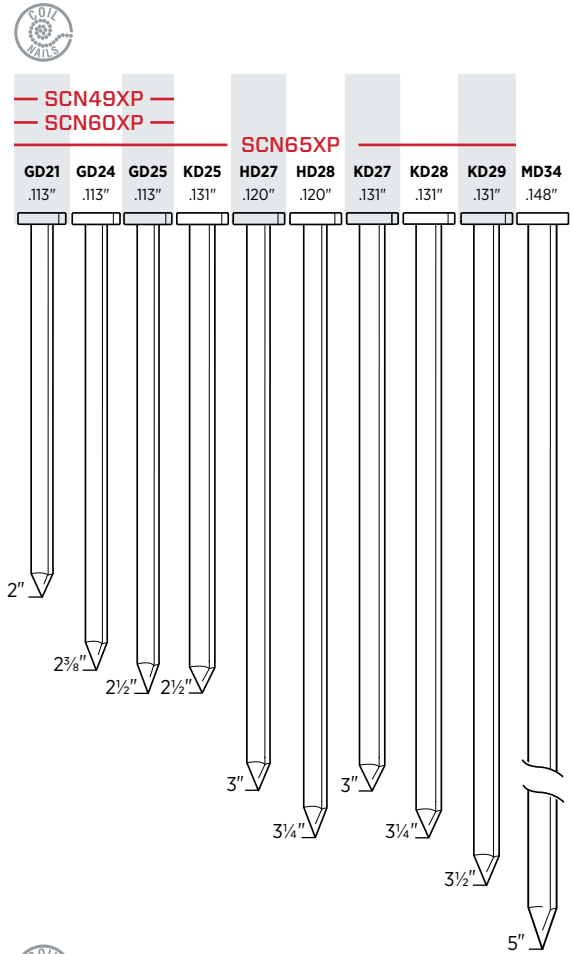

15° Ring-Shank Coil Nails

Framing, sheathing, pallets, subfloor, decks and trusses						
Length	Point	Finish	Coating	Collation	Box Count	Item Code
2" x .099"	Diamond	Bright	Sencote	Angular, flat wire wound	6.6M	BL21APBF
2" x .099"	Diamond	Bright	Sencote	Angular, flat wire wound	6.6M	BT21APBF
2" x .113"	Diamond	Bright	Sencote	Angular, flat wire wound	6M	GL21APBF
2 1/4" x .099"	Diamond	Bright	Sencote	Angular, flat wire wound	6.6M	BL23APBF
2 3/8" x .113"	Diamond	Bright	Sencote	Angular, flat wire wound	6M	GL24APBF
2 1/4" x .099"	Diamond	Galv	Sencote	Angular, flat wire wound	6.6M	BE23AABF
2 3/8" x .113"	Diamond	Galv	Sencote	Angular, flat wire wound	6M	GL24AABF
2 3/8" x .113"	Diamond	Hot Dip	Sencote	Angular, flat wire wound	2.7M	GL24ASBF
3" x .120"	Diamond	Galv	Sencote	Angular, flat wire wound	3.6M	HL27AABF
3" x .120"	Diamond	Hot Dip	Sencote	Angular, flat wire wound	2.4M	HL27ASBF
2 3/8" x .113"	Diamond	Stainless	Sencote	Angular, flat wire wound	2.7M	GL24AGBF
3" x .120"	Diamond	Stainless	Sencote	Angular, flat wire wound	2.4M	HL27AGBF

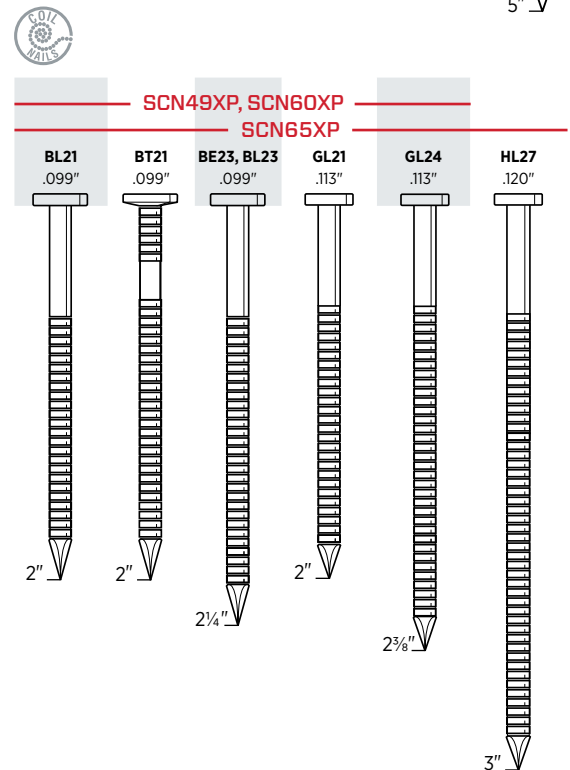

FRAMING, SHEATHING & SUBFLOOR FASTENERS

15° Screw-Shank Coil Nails

Framing, sheathing, pallets, subfloor, decks and trusses						
Length	Point	Finish	Coating	Collation	Box Count	Item Code
2" x .099"	Blunt Dia.	Bright	Sencote	Angular, flat wire wound	9M	BK21BPBFN
2" x .099"	Chisel	Bright	Sencote	Angular, flat wire wound	6.6M	BK21EPBF
2¼" x .099"	Blunt Dia.	Bright	Sencote	Angular, flat wire wound	9M	BK23BPBFN
2¼" x .099"	Chisel	Bright	Sencote	Angular, flat wire wound	6.6M	BK23EPBF
2½" x .099"	Blunt Dia.	Bright	Sencote	Angular, flat wire wound	6M	BK25BPBFN
3" x .120"	Diamond	Bright	Sencote	Angular, flat wire wound	4M	HK27APBFN

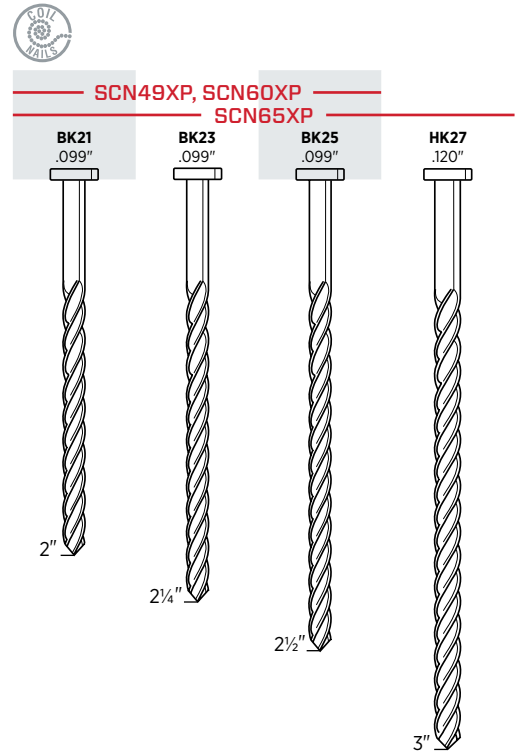

15° Smooth-Shank Stiff-Stock Coil Nails

Wood to masonry						
Length	Point	Finish	Coating	Collation	Box Count	Item Code
1½" x .099"	Diamond	Bright	Sencote	Angular, flat wire wound	3M	M003011
2¼" x .099"	Diamond	Bright	Sencote	Angular, flat wire wound	3M	M003012

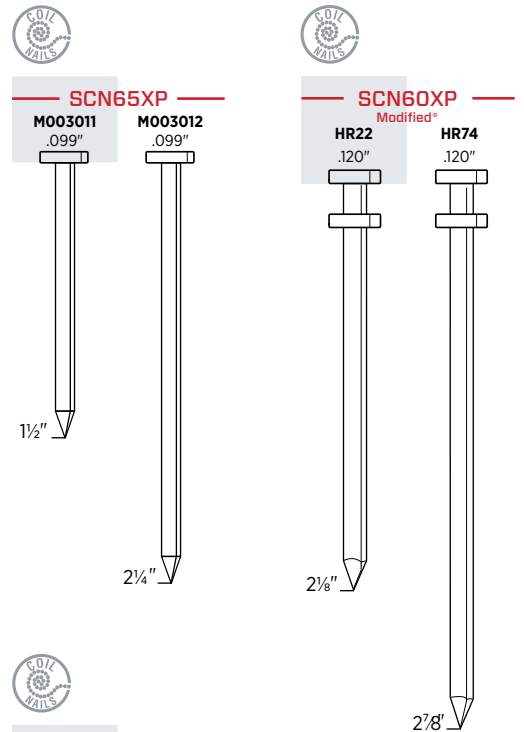

15° Duplex Smooth-Shank Coil Nails

Framing, trusses, crating and concrete forms						
Length	Point	Finish	Coating	Collation	Box Count	Item Code
2½" x .120"	Diamond	Bright	Plain	Angular, flat wire wound	5.4M	HR22APAF
2⅞" x .120"	Diamond	Bright	Plain	Angular, flat wire wound	3.6M	HR74APAF

*Requires a special order modified CN60XP tool (order XA1739)

15° Drywall Ring-Shank Bugle-Head Coil Nails

Drywall to wood						
Length	Point	Finish	Coating	Collation	Box Count	Item Code
1½" x .099"	Diamond	Galv	Plain	Angular, conical wire wound	9.6M	BG17AAA
1½" x .099"	Diamond	Galv	Plain	Angular, conical wire wound	6.4M	BG17AAAQ
1⅝" x .099"	Diamond	Galv	Plain	Angular, conical wire wound	9.6M	BG18AAA
1⅝" x .099"	Diamond	Galv	Plain	Angular, conical wire wound	6.4M	BG18AAAQ

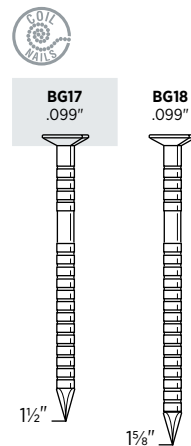

FRAMING, SHEATHING & SUBFLOOR FASTENERS

Collated Concrete and Steel Collated Pins

For fastening drywall track, wood furring, hat channel, metal washers or ceiling grids to concrete, concrete block and steel

Length	Point	Finish	Coating	Collation	Box Count	Item Code
½" x .109"/.118"	Pinched	Zinc Plated	Plain	Standard Washer Style	1M	W3050YXS
¾" x .109"	Pinched	Black Oxide	Plain	Standard Washer Style	1M	W3075PXC
¾" x .109"	Pinched	Zinc Plated	Plain	Standard Washer Style	1M	W3075YXC
1" x .109"	Pinched	Zinc Plated	Plain	Standard Washer Style	1M	W3100YXC
1¼" x .109"	Pinched	Zinc Plated	Plain	Standard Washer Style	1M	W3125YXC

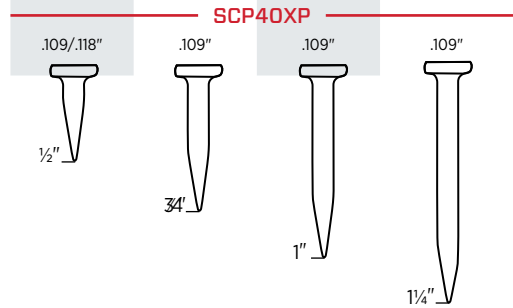

34° Heat-Treated Metal Connector Nails

Joist hangers, foundation anchors, seismic and hurricane straps and ties

Length	Point	Finish	Coating	Collation	Box Count	Item Code
1½" x .131"	Diamond	Bright	Plain	34° Paper tape, strip	2M	KJ17AHBD
1½" x .148"	Diamond	Bright	Plain	34° Paper tape, strip	2M	MD17AHBD
2½" x .131"	Diamond	Bright	Plain	34° Paper tape, strip	2M	KJ25AHBD
2½" x .148"	Diamond	Bright	Plain	34° Paper tape, strip	1.5M	MD25AHBD
2½" x .162"	Diamond	Bright	Plain	34° Paper tape, strip	1.2M	ND25AHBD
1½" x .131"	Diamond	Hot Dip	Plain	34° Paper tape, strip	2M	KJ17AEBD
1½" x .148"	Diamond	Hot Dip	Plain	34° Paper tape, strip	2M	MD17AEBD
2½" x .131"	Diamond	Hot Dip	Plain	34° Paper tape, strip	2M	KJ25AEBD
2½" x .148"	Diamond	Hot Dip	Plain	34° Paper tape, strip	1.5M	MD25AEBD
2½" x .162"	Diamond	Hot Dip	Plain	34° Paper tape, strip	1.2M	ND25AEBD

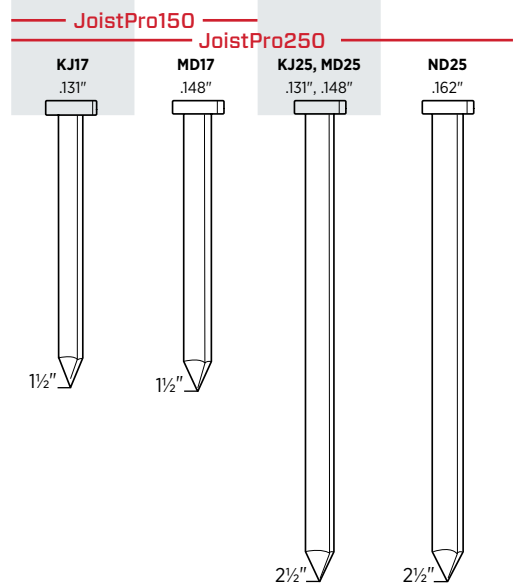

34° Non-Heat-Treated Metal Connector Nails

Joist hangers, foundation anchors, seismic and hurricane straps and ties, standard tensile, non-hardened nails for use in joists

Length	Point	Finish	Coating	Collation	Box Count	Item Code
1½" x .131"	Diamond	Bright	Plain	34° Paper tape, strip	2M	M0002261
1½" x .148"	Diamond	Bright	Plain	34° Paper tape, strip	2M	M0002263
2½" x .148"	Diamond	Bright	Plain	34° Paper tape, strip	1.5M	M0002265
2½" x .162"	Diamond	Bright	Plain	34° Paper tape, strip	1.2M	M0002267
1½" x .131"	Diamond	Hot Dip	Plain	34° Paper tape, strip	2M	M0002262
1½" x .148"	Diamond	Hot Dip	Plain	34° Paper tape, strip	2M	M0002264
2½" x .148"	Diamond	Hot Dip	Plain	34° Paper tape, strip	1.5M	M0002266
2½" x .162"	Diamond	Hot Dip	Plain	34° Paper tape, strip	1.2M	M0002268

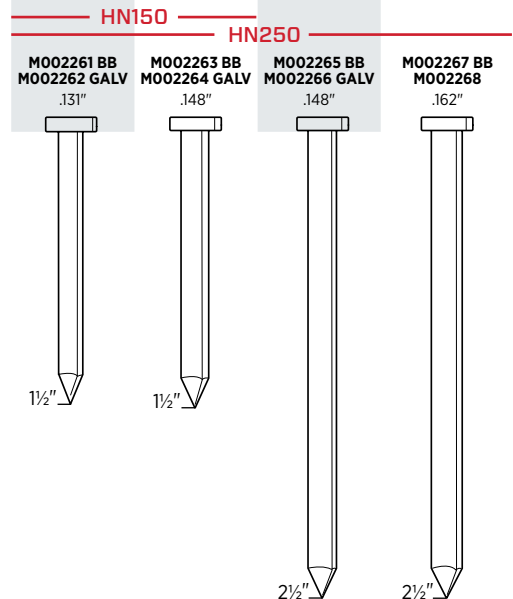

FRAMING, SHEATHING & SUBFLOOR FASTENERS

16^{GA} 1" Crown Heavy Wire Staples

Sheathing, house wrap, composite roofing, roofing felt, corrugated containers, foam insulation board, furniture/cabinet frames and butt joints

Length	Point	Finish	Coating	Collation	Box Count	Item Code
3/8"	Chisel	Galv	Plain	Glued	10M	P06BAA
1/2"	Chisel	Galv	Sencote	Taped	10M	P08BABT
5/8"	Chisel	Galv	Sencote	Taped	10M	P10BAB
5/8"	Divergent	Galv	Sencote	Glued	10M	P10FAB
5/8"	Chisel	Galv	Coated	Glued	10M	P10BPE
3/4"	Chisel	Galv	Sencote	Taped	10M	P11BAB
3/4"	Chisel	Galv	Coated	Glued	10M	P11BPE
7/8"	Chisel	Galv	Sencote	Taped	10M	P12BAB
1"	Chisel	Galv	Sencote	Taped	10M	P13BAB
1"	Chisel	Galv	Sencote	Glued	10M	P13BPE
1 1/4"	Chisel	Galv	Sencote	Taped	10M	P15BAB
1 1/4"	Chisel	Galv	Coated	Glued	10M	P15BPE
1 1/2"	Chisel	Galv	Sencote	Taped	10M	P17BAB
1 3/4"	Chisel	Galv	Sencote	Taped	5M	P19BAB
2"	Chisel	Galv	Sencote	Taped	5M	P21BAB
1"	Outside Chisel	Stainless	Sencote	Taped	5M	P13BGBN

*WC150XP short staples: order block-out kit YK0786 to drive staples under 5/8"

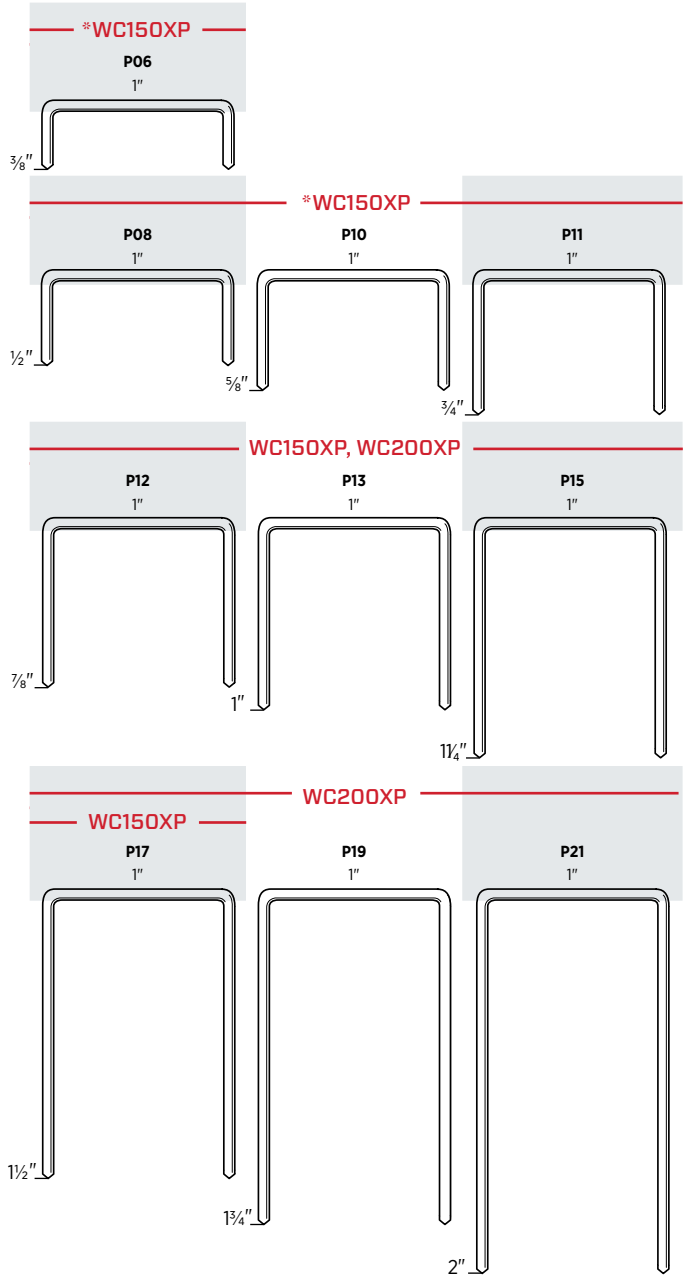

17^{GA} 7/16" Crown Heavy Wire Staples

Sheathing, subfloor, furniture frames and crates

Length	Point	Finish	Coating	Collation	Box Count	Item Code
1 1/4"	Chisel	Bright	Sencote	Glued	10M	O15BRBB
1 3/8"	Chisel	Bright	Sencote	Glued	10M	O16BRBB
1 1/2"	Chisel	Bright	Sencote	Glued	10M	O17BRBB
1 5/8"	Chisel	Bright	Sencote	Glued	10M	O18BRBB
1 3/4"	Chisel	Bright	Sencote	Glued	10M	O19BRBB

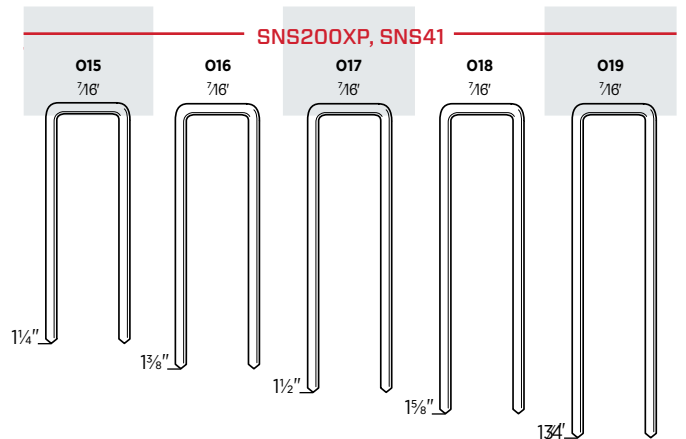

FRAMING, SHEATHING & SUBFLOOR FASTENERS

16^{GA}

7/16" Crown Heavy Wire Staples

Sheathing, soffits, underlayment, lattice, cabinets, casebacks and drawers

Length	Point	Finish	Coating	Collation	Box Count	Item Code
3/4"	Chisel	Bright	Sencote	Glued	5M	N11BRB
1"	Chisel	Bright	Sencote	Glued	5M	N13BRB
1 1/8"	Chisel	Bright	Sencote	Tape	10M	N14BRB
1 1/4"	Chisel	Bright	Sencote	Tape	10M	N15BRB
1 3/8"	Chisel	Bright	Sencote	Tape	10M	N16BRB
1 3/8"	Step	Bright	Sencote	Glued	10M	N16RRB
1 1/2"	Chisel	Bright	Sencote	Tape	10M	N17BRB
1 5/8"	Chisel	Bright	Sencote	Tape	10M	N18BRB
1 3/4"	Chisel	Bright	Sencote	Tape	10M	N19BRB
2"	Chisel	Bright	Sencote	Tape	10M	N21BRB
1/2"	Chisel	Galv	Sencote	Glued	5M	N08BABN
1/2"	Chisel	Galv*	Sencote	Glued	5M	N08BBBN
1/2"	Diverg	Galv*	Sencote	Glued	5M	N08FBB
5/8"	Chisel	Galv*	Sencote	Glued	5M	N10BAB
3/4"	Chisel	Galv	Sencote	Glued	5M	N11BAB
3/4"	Diverg	Galv*	Sencote	Glued	5M	N11FBB
7/8"	Chisel	Galv	Sencote	Glued	5M	N12BABN
7/8"	Diverg	Galv	Sencote	Glued	5M	N12FABN
1"	Chisel	Galv	Sencote	Glued	5M	N13BAB
1"	Diverg	Galv	Sencote	Glued	5M	N13FAB
1 1/8"	Chisel	Galv	Sencote	Tape	10M	N14BAB
1 1/8"	Diverg	Galv	Sencote	Glued	10M	N14FAB
1 1/4"	Chisel	Galv	Sencote	Tape	10M	N15BAB
1 1/4"	Diverg	Galv	Sencote	Glued	10M	N15FAB
1 3/8"	Chisel	Galv	Sencote	Tape	10M	N16BAB
1 1/2"	Chisel	Galv	Sencote	Tape	10M	N17BAB
1 1/2"	Chisel	Galv	Sencote	Glued	10M	N17BPE
1 5/8"	Chisel	Galv	Sencote	Tape	10M	N18BAB
1 3/4"	Chisel	Galv	Sencote	Tape	10M	N19BAB
1 3/4"	Chisel	Galv	Sencote	Glued	10M	N19BPE
2"	Chisel	Galv	Sencote	Tape	10M	N21BAB
2"	Chisel	Galv	Sencote	Glued	10M	N21BPE
1 1/4"	Chisel	Stainless	Sencote	Glued	3M	N15BGB
1 1/2"	Chisel	Stainless	Sencote	Glued	3M	N17BGB
1 3/4"	Chisel	Stainless	Sencote	Glued	3M	N19BGBN
2"	Chisel	Stainless	Sencote	Glued	3M	N21BGBN

*Galvanized High-tensile

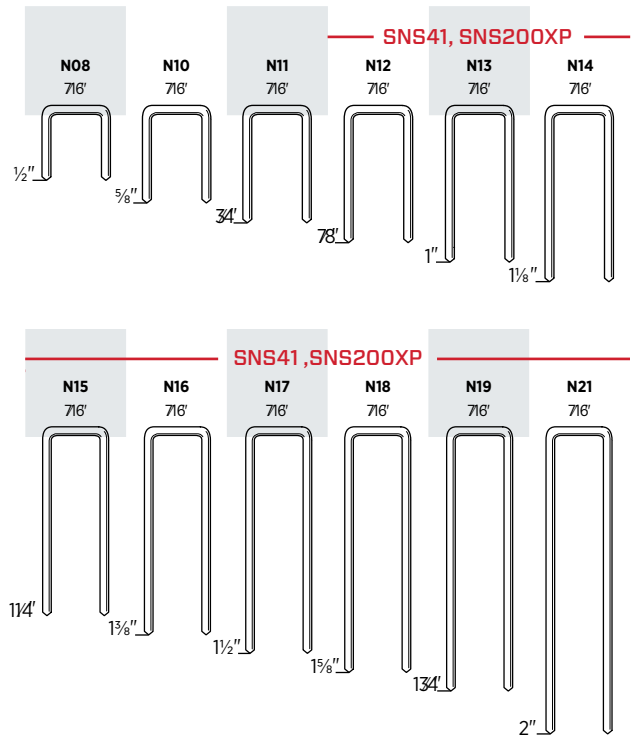

15^{GA}

7/16" Crown Heavy Wire Staples

Framing, sheathing, subflooring, decking, lathing, door and window units, fencing, pallets, crate & box assembly, furring and furniture framing

Length	Point	Finish	Coating	Collation	Box Count	Item Code
1 1/2"	Chisel	Bright	Sencote	Taped	5M	Q17BRB
1 3/4"	Chisel	Bright	Sencote	Taped	5M	Q19BRB
2"	Chisel	Bright	Sencote	Taped	5M	Q21BRB
2 1/4"	Chisel	Bright	Sencote	Taped	5M	Q23BRB
2 1/2"	Chisel	Bright	Sencote	Taped	5M	Q25BRB
1 1/4"	Chisel	Galv	Sencote	Taped	5M	Q15BAB
1 1/2"	Chisel	Galv	Sencote	Taped	5M	Q17BAB
1 3/4"	Chisel	Galv	Sencote	Taped	5M	Q19BAB
2"	Chisel	Galv	Sencote	Taped	5M	Q21BAB
2 1/4"	Chisel	Galv	Sencote	Taped	5M	Q23BAB
2 1/2"	Chisel	Galv	Sencote	Taped	5M	Q25BAB
1 3/4"	Chisel	Stainless	Sencote	Taped	2.2M	Q19BGBN
2 1/2"	Chisel	Stainless	Sencote	Taped	1M	Q25BGBN

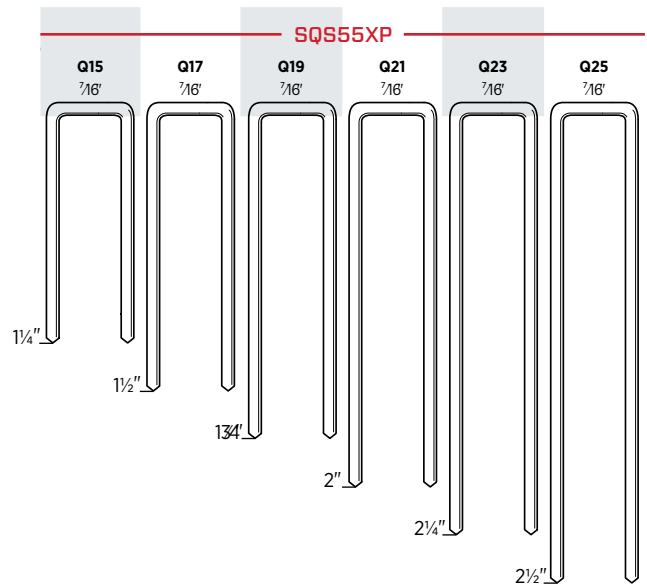

WE COVER IT ALL

When it comes to roofing applications or installing siding, uptime is everything. SENCO has designed a full line of tools and fasteners to maximize your productivity.

Our new RoofPro™445XP with its innovative firing valve uses 5% less air. A bi-metal driver blade improves durability. And our power in, power out feed system is air driven for stability and speed.

APPLICATIONS

SESCO offers a variety of coil nailers and crown staplers with fasteners optimized for different types of shingles, siding, sheathing, and felt underlayment.

FEATURES

- High-strength housings
- Long-lasting wear plates
- Easy, one-handed operation for increased productivity
- Adjustable depth-of-drive



RoofPro™455XP

13/4" COIL NAILER

ITEM# 3D0101N

15°



Features

- Hardened wear plates and safety for extended reliability and parts life
- Adjustable nail canister accepts entire range of roofing nail
- Metal wear plate in nail canister reduces canister wear and improves nail feed
- Adjustable shingle guide

RoofPro™445XP

13/4" COIL NAILER

ITEM# 8V0001N

15°



Features

- Innovative firing valve reduces air consumption without compromising power or speed
- Bi-metal driver blade reduces wear and improves durability
- Power in, power out feed system improves speed and delivers consistent drives
- Metal wear plate in nail canister reduces canister wear and helps improve nail feed
- Adjustable and removable shingle guide

SCN49XP

2 1/2" COIL NAILER

ITEM# 5J0001N

15°



Features

- Well-balanced and lightweight
- Dual Collation allows choice between wire or plastic collation
- High load capacity



It doesn't cost a bundle to drive the very best.



— **Building Code Approved.**

— **Professional Performance.**

Product Reference Chart

TOOL SPECS	RoofPro™455XP	RoofPro™445XP	SCN49XP
Trigger	Sequential	Sequential	Selectable
Op. Pressure	70-120 psi (4.8-8.3 bar)	70-120 psi (4.8-8.3 bar)	70-120 psi (4.8-8.3 bar)
Air Consumption (60CPM)	6.54 scfm	3.86 scfm	3.9 scfm
Air Inlet	1/4" NPT	1/4" NPT	3/8" NPT
Weight	5.4 lbs (2.5 kg)	5.2 lbs (2.35 kg)	5.1 lbs (2.31 kg)
Height	10.5" (267 mm)	10.9" (276 mm)	12" (304 mm)
Length	10.25" (260 mm)	10.6" (269 mm)	12.25" (314 mm)
Width	4.5" (114 mm)	4.5" (114 mm)	5.19" (132 mm)
Main Body Material	Aluminum	Aluminum	Magnesium
Warranty	5 yrs	5 yrs	5 yrs
FASTENER SPECS	Fasteners are located on pages 49 - 51		
Capacity	120	120	250-375
Range	3/4"-13/4"	3/4"-13/4"	11/4"-21/2"
Shank	.120"	.120"	.082"-11/32"
Angled/Collation	15° Angled, Flat Wire Coil	15° Angled, Flat Wire Coil	15° Angled Flat Wire Coil or Plastic Carrier Strip
Series	HJ, M00	HJ, M00	BE, BK, BL, BT, ED, EL, GD, GL, SE
TOOL FEATURES			
Tool-Free Depth-of-Drive	Yes	Yes	Yes
Tool-Free Jam Clearing	Yes	Yes	Yes
Adjustable Exhaust	Yes	No	Yes

WC150RXP

1" CROWN 11/2" ROOFING STAPLER

ITEM# 4X0001N

16_{GA}



Features

- High-strength composite magazine
- EZ-Clear™ Latch virtually eliminates downtime caused by fastener jams
- Hardened wear plates and safety for extended reliability and parts life

BC58

12" CROWN 5/8" STAPLE + 1" BUTTON CAP

ITEM# 4A0001N

21_{GA}



Features

- EZ-Load system for staples and caps
- Ultra-lightweight for ease of use and maneuverability
- Balanced and fast for greater productivity
- Side-mount cap collar holds caps regardless of tool position

A11

7/16" CROWN 3/8" HAMMER STAPLER

ITEM# PC0700

20_{GA}



Features

- Rugged all-steel construction
- Easy to service and maintain
- Comfortable fluted handle with grip

Product Reference Chart

TOOL SPECS	WC150RXP	BC58	A11
Trigger	Contact	Contact	—
Op. Pressure	70 - 120 psi (4.8 - 8.3 bar)	60 - 95 psi (4.1 - 6.5 bar)	—
Air Consumption (60CPM)	3.18 scfm	.77 scfm	—
Air Inlet	3/8" NPT	1/4" NPT	—
Weight	5.5 lbs (2.5 kg)	4.1 lbs (2 kg)	2 lbs (.9 kg)
Height	9" (229 mm)	8.5" (216 mm)	1.75" (44.4 mm)
Length	15.25" (387 mm)	12.5" (317 mm)	12.3" (312.4 mm)
Width	4" (105 mm)	3.5" (89 mm)	—
Main Body Material	Aluminum	Aluminum	Steel
Warranty	5 yrs	5 yrs	1 yr
FASTENER SPECS	Fasteners are located on pages 49 - 51		
Capacity	160	110	168
Range	5/8" - 11/2"	5/8" Galv.	3/8"
Crown	1"	1/2"	7/16"
Gauge/Collation	16 Ga. Straight Glued and Taped Strip	21 Ga.	20 Ga.
Series	P	M004092, Button Cap	H
TOOL FEATURES			
Tool-Free Depth-of-Drive	Yes	No	—
Tool-Free Jam Clearing	Yes	No	Yes
Adjustable Exhaust	No	Yes	—

ROOFING & SIDING FASTENERS

15° Smooth-Shank Coil Nails

Siding, asphalt and fiberglass shingles, and vapor barriers

Length	Point	Finish	Coating	Collation	Box Count	Item Code
3/4" x .120"	Diamond	Galv	Plain	Angular, flat wire coil	7.2M	M003101
7/8" x .120"	Diamond	Galv	Plain	Angular, flat wire coil	7.2M	M003102
1" x .120"	Diamond	Galv	Plain	Angular, flat wire coil	7.2M	M003103
1 1/4" x .120"	Diamond	Hot Dip	Plain	Angular, flat wire coil	7.2M	HJ15ASAP
1 1/4" x .120"	Diamond	Galv	Plain	Angular, flat wire coil	7.2M	M003104
1 1/2" x .120"	Diamond	Galv	Plain	Angular, flat wire coil	7.2M	M003105
1 3/4" x .120"	Diamond	Galv	Plain	Angular, flat wire coil	7.2M	M003106

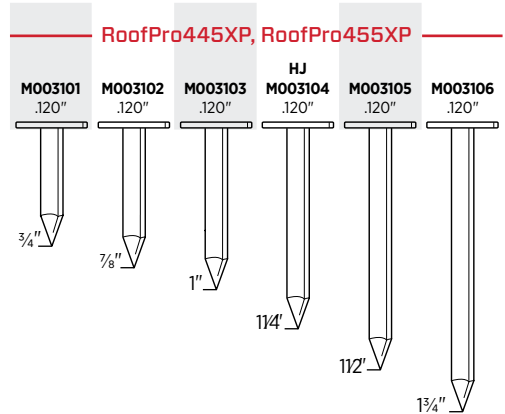

Vinyl Siding Attachment (sold separately)

Convert RoofPro 445XP and RoofPro 455XP into vinyl siding nailer

Fits Tool	Item Code
RoofPro 445XP	HA0308
RoofPro 455XP	MA0013



15° Smooth-Shank Coil Nails

Siding, packaging, fencing, pallets and underlayment

Length	Point	Finish	Coating	Collation	Box Count	Item Code
1½" x .099"	Diamond	Bright	Sencote	Angled plastic carrier coil	6M	BD17APBC
1¾" x .092"	Diamond	Hot Dip	Sencote	Angled plastic carrier coil	3.6M	ED19ASBC
2" x .092"	Diamond	Galv	Sencote	Angled flat wire coil	3.6M	ED21AABH
2" x .092"	Diamond	Exterior	Sencote	Angled flat wire coil	3.6M	ED21ADBH
2" x .092"	Diamond	Exterior	Sencote	Angled flat wire coil	7.2M	EJ21ADBH
2" x .092"	Diamond	Hot Dip	Sencote	Angled plastic carrier coil	3.6M	EJ21ASBC
2¼" x .092"	Diamond	Galv	Sencote	Angled flat wire coil	3.6M	ED23AABH
2¼" x .092"	Diamond	Exterior	Sencote	Angled flat wire coil	3.6M	ED23ADBH
2¼" x .092"	Diamond	Hot Dip	Sencote	Angled plastic carrier coil	3.6M	ED23ASBC
2¼" x .092"	Diamond	Exterior	Sencote	Angled conical wire coil	7.2M	EJ23ADBH
2¼" x .092"	Diamond	Hot Dip	Sencote	Angled plastic carrier coil	3.6M	EJ23ASBC

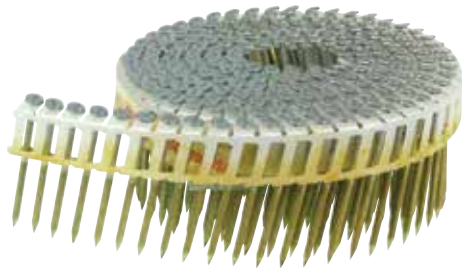

Angled Plastic Carrier Coil

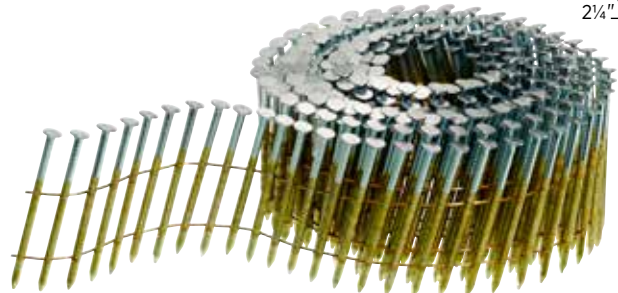

Angled Wire Coil

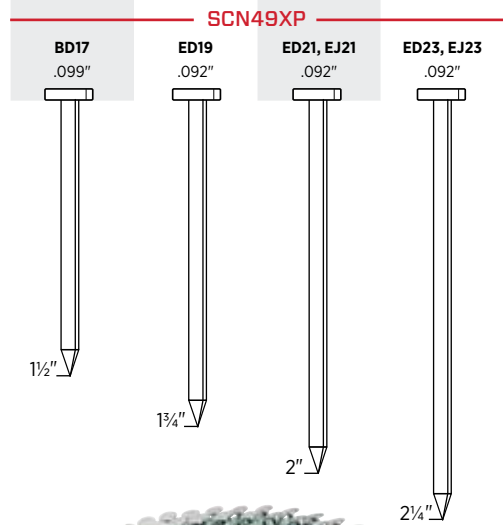

15° Ring-Shank Coil Nails

Siding, packaging, fencing, wood shingles, crating and pallets

Length	Point	Finish	Coating	Collation	Box Count	Item Code
1¼" x .082	Diamond	Bright	Sencote	Angled, conical wire coil	15M	SE15APB
1¼" x .082	Diamond	Bright	Sencote	Angled flat wire coil	14M	SE15APBH
1½" x .082	Diamond	Bright	Sencote	Angled conical wire coil	12M	SE17APB
1½" x .082	Diamond	Bright	Sencote	Angled, flat wire coil	11.2M	SE17APBH
1¾" x .082	Diamond	Bright	Sencote	Angled conical wire coil	12M	SE19APB
1½" x .092	Diamond	Exterior	Sencote	Angled flat wire coil	9M	EL17ADBH
1¾" x .092	Diamond	Hot Dip	Sencote	Angled plastic carrier coil	3.6M	EL19ASBC
1¾" x .092	Diamond	Hot Dip	Sencote	Angled flat wire coil	3.6M	EL19ASBH
17/8" x .092	Diamond	Galv	Sencote	Angled flat wire coil	3.6M	EL20AABH
17/8" x .092	Diamond	Hot Dip	Sencote	Angled flat wire coil	3.6M	EL20ASBH
2" x .092	Diamond	Exterior	Sencote	Angled flat wire coil	9M	EL21ADBH
2" x .092	Diamond	Hot Dip	Sencote	Angled flat wire coil	3.6M	EL21ASBH
2¼" x .092	Diamond	Galv	Sencote	Angled flat wire coil	3.6M	EL23AABH
2¼" x .092	Diamond	Hot Dip	Sencote	Angular, plastic carrier coil	3.6M	EL23ASBC
2¼" x .092	Diamond	Hot Dip	Sencote	Angled flat wire coil	3.6M	EL23ASBH
1¾" x .092	Diamond	Stainless	Sencote	Angled flat wire coil	3.6M	EL19AGBH
17/8" x .092	Diamond	Stainless	Sencote	Angled flat wire coil	3.6M	EL20AGBH
2" x .092	Diamond	Stainless	Sencote	Angled flat wire coil	3.6M	EL21AGBH
2¼" x .092	Diamond	Stainless	Sencote	Angled flat wire coil	3.6M	EL23AGBH

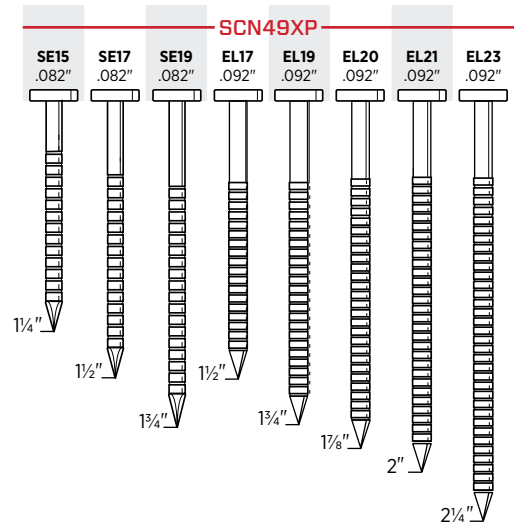

ROOFING & SIDING FASTENERS

16^{GA} 1" Crown Heavy Wire Staples

Composite roofing, roofing felt, foam insulation board, house wrap, sheathing, corrugated containers, furniture/cabinets and butt joints

Length	Point	Finish	Coating	Collation	Box Count	Item Code
3/8"	Chisel	Galv	Plain	Glued	10M	P06BAA
1/2"	Chisel	Galv	Sencote	Taped	10M	P08BABT
5/8"	Chisel	Galv	Sencote	Taped	10M	P10BAB
5/8"	Divergent	Galv	Sencote	Glued	10M	P10FAB
5/8"	Chisel	Galv	Coated	Glued	10M	P10BPE
3/4"	Chisel	Galv	Sencote	Taped	10M	P11BAB
3/4"	Chisel	Galv	Coated	Glued	10M	P11BPE
7/8"	Chisel	Galv	Sencote	Taped	10M	P12BAB
1"	Chisel	Galv	Sencote	Taped	10M	P13BAB
1"	Chisel	Galv	Sencote	Glued	10M	P13BPE
1 1/4"	Chisel	Galv	Sencote	Taped	10M	P15BAB
1 1/4"	Chisel	Galv	Coated	Glued	10M	P15BPE
1 1/2"	Chisel	Galv	Sencote	Taped	10M	P17BAB
1"	Outside Chisel	Stainless	Sencote	Taped	5M	P13BGBN

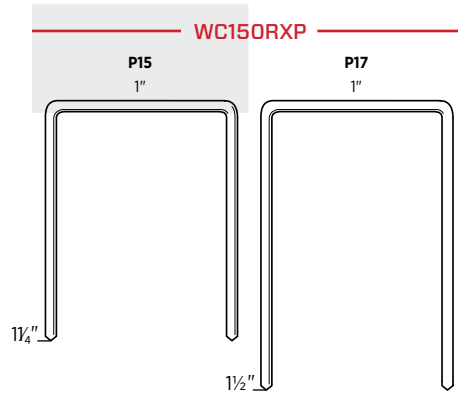
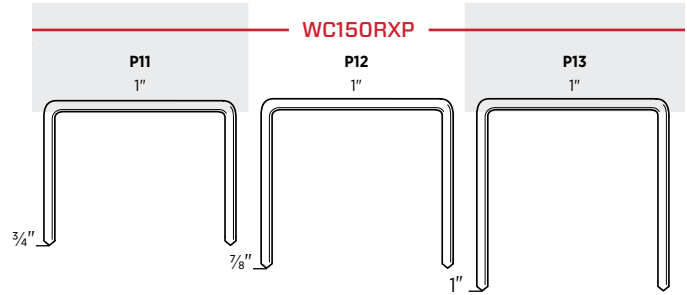
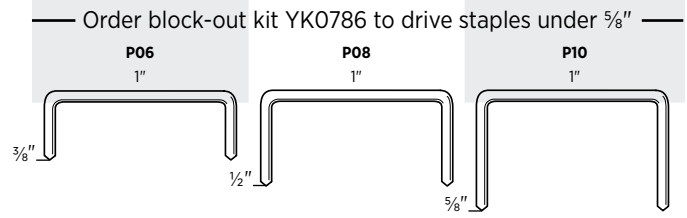

20^{GA} 7/16" Crown Fine Wire Staples

Roofing, insulation and vapor barriers

Length	Point	Finish	Coating	Collation	Box Count	Item Code
3/8"	Chisel	Galv	Plain	Glued	5M	H06BAA

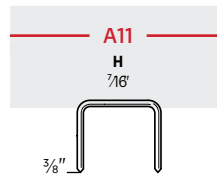

21^{GA} 1" Button Cap & 1/2" Crown Staples

Roof felt installation and house wrap

Length	Point	Finish	Coating	Collation	Box Count	Item Code
5/8"	Chisel	Galv	Plain	Glued	2.2M	M004092
1"	—	Plastic	—	Laser Weld	2.2M	—

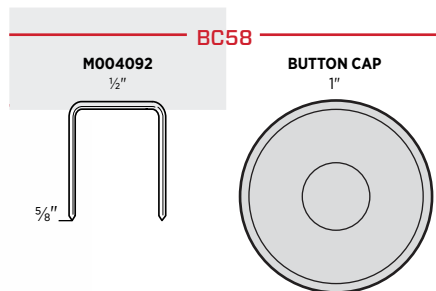

PALLETS & CRATING

THE DURABILITY TO DRIVE ALL DAY

SENCO's PalletPro™ heavy-duty coil nailers are built specifically for the challenges of pallets and crating. The PalletPro130 can drive as long as 5-1/4" fasteners and hold up to 225 nails.

APPLICATIONS

Pallets, crates, heavy duty-framing and truss attachment

FEATURES

- Durable drivers and bumpers
- Flexible collation deflectors
- Dust guards for safe operation and extended use

Clinch and Sisal Anvil Staple tools come in 18 and 20 gauge 1/2" and 7/16" crowns. Great for hand-held or mounted applications.

APPLICATIONS

Packaging, corrugated box fabrication, shoe making and bedding and wherever two materials must be stapled and clinched together

FEATURES

- High-capacity magazines
- Extended reach capability
- Tool-free adjustable anvil opening
- Bottom-load magazines



PalletPro™57FXP

2 1/4" COIL NAILER

ITEM# 4L0001N

15°



Features

- High load capacity
- Ultra-durable driver and piston bumper for long life
- Adjustable nail canister accommodates wide range of nails
- Body protection — side steel wear plates reduce abrasion of tool

PalletPro™100XP

4" COIL NAILER (SPECIAL-ORDER TOOL)

ITEM# 5L0001N

15°



Features

- High load capacity
- Includes heavy-duty threaded T-handle for use when appropriate, or removal when not desired
- Flexible collation deflector and dust guard for improved safety in commercial environments
- Strengthened driver and bumper for extended use and reliable service

PalletPro™130XP

5 1/8" COIL NAILER (SPECIAL-ORDER TOOL)

ITEM# 5M0001N

15°



Features

- High load capacity
- Includes heavy-duty threaded T-handle for use when appropriate, or removal when not desired
- Flexible collation deflector and dust guard for improved safety in commercial environments
- Strengthened driver and bumper for extended use and reliable service

Product Reference Chart

TOOL SPECS	PalletPro™57XP	PalletPro™100XP	PalletPro™130XP
Trigger	Contact	Contact	Sequential
Op. Pressure	70-120 psi (4.9-8.4 bar)	70-120 psi (4.9-8.4 bar)	70-120 psi (4.9-8.4 bar)
Air Consumption (60CPM)	3.07 scfm	11.4 scfm	11.4 scfm
Air Inlet	3/8" NPT	3/8" NPT	3/8" NPT
Weight	5.9 lbs (2.67 kg)	11.5 lbs (5.24 kg)	13 lbs (5.9 kg)
Height	11.25" (286 mm)	16.5" (418 mm)	18" (457 mm)
Length	11.88" (302 mm)	13.25" (338 mm)	13" (330 mm)
Width	5.25" (123 mm) Aluminum	6" (153 mm)	6.6" (168 mm)
Main Body Material	5 yrs	Aluminum	Aluminum
Warranty		5 yrs	5 yrs
FASTENER SPECS	Fasteners are located on pages 55 -		
Capacity	300-350	225-300	120-225
Range	1"-2 1/4"	2 1/4" - 4"	3"-5 1/8"
Shank	.082"-.092"	.099"-.148"	.120"-.148"
Angled/Collation	15° angled, flat wire coil	15° angled, flat wire coil	15° angled, flat wire coil HD, HK,
Series	BK, ED, EJ, EL, SE	BE, BK, BL, BT, HK, GD, GL, HD, HL, KD	HL, KD, MD
TOOL FEATURES			
Tool-Free Jam Clearing	Yes	Yes	Yes
Tool-Free Depth-of-Drive	No	No	No
Debris Shield	Yes	Yes	Yes

DFPXP

20 Ga. 1/2" CROWN, 1/2" STAPLE
CLINCH TOOL

ITEM# 8H0001N

20_{GA}



Features

- High-capacity magazine — less reloading means greater productivity
- Tool-free adjustable anvil opening
- Rubber comfort grip reduces vibration, slipping and fatigue
- Bottom-load magazine for quick reloading
- 6.9" throat allows for extended reach into cartons

F75LXP

18 Ga. 7/16" CROWN, 5/8" STAPLE
CLINCH TOOL

ITEM# 8J0002N

18_{GA}



Features

- High-capacity magazine — less reloading means greater productivity
- Tool-free adjustable anvil opening
- Rubber comfort grip reduces vibration, slipping and fatigue
- Bottom-load magazine for quick reloading
- 6.9" throat allows for extended reach into cartons

F75SXP

18 Ga. 7/16" CROWN, 5/8" STAPLE
SISAL ANVIL

ITEM# 8J0001N

18_{GA}



Features

- High-capacity magazine — less reloading means greater productivity
- Tool-free adjustable anvil opening
- Rubber comfort grip reduces vibration, slipping and fatigue
- Bottom-load magazine for quick reloading

Product Reference Chart

TOOL SPECS	DFPXP	F75LXP	F75SXP
Trigger	Sequential	Sequential	Sequential
Op. Pressure	65-100 psi (4-7 bar)	65-100 psi (4-7 bar)	65-100 psi (4-7 bar)
Air Consumption (60CPM)	.7 scfm	.7 scfm	.8 scfm
Air Inlet	1/4" NPT	1/4" NPT	1/4" NPT
Weight	4.9 lbs (2.24 kg)	4.9 lbs (2.24 kg)	4.9 lbs (2.24 kg)
Height	12.9" (327 mm)	12.9" (327 mm)	12.9" (327 mm)
Length	14.9" (380 mm)	14.9" (380 mm)	14.9" (380 mm)
Width	3" (75 mm)	3" (75 mm)	3" (75 mm)
Main Body Material	Alumimum	Aluminum	Aluminum
Warranty	5 yrs	5 yrs	5 yrs
FASTENER SPECS	Fasteners are located on pages 55 - 57		
Capacity	230	152	152
Range	5/16" - 5/8"	5/16" - 5/8"	5/16" - 5/8"
Crown	1/2"	7/16"	7/16"
Gauge/Collation	20 Ga. Glued Strip	18 Ga. Glued Strip	18 Ga. Glued Strip
Series	F	J	J
TOOL FEATURES			
Tool-Free Adjustable Anvil Opening	Yes	Yes	Yes
Bottom-Load Magazine Extended	Yes	Yes	Yes
Reach Capability	Yes	Yes	No

PALLETS & CRATING FASTENERS

15° Smooth-Shank Coil Nails

Pallets, crates, fencing, siding and underlayment

Length	Point	Finish	Coating	Collation	Box Count	Item Code
2" x .092"	Diamond	Galv	Sencote	Angled flat wire coil	3.6M	ED21AABH
2" x .092"	Diamond	Exterior	Sencote	Angled flat wire coil	3.6M	ED21ADBH
2" x .092"	Diamond	Exterior	Sencote	Angled flat wire coil	7.2M	EJ21ADBH
2¼" x .092"	Diamond	Galv	Sencote	Angled flat wire coil	3.6M	ED23AABH
2¼" x .092"	Diamond	Exterior	Sencote	Angled flat wire coil	3.6M	ED23ADBH



PAL57XP

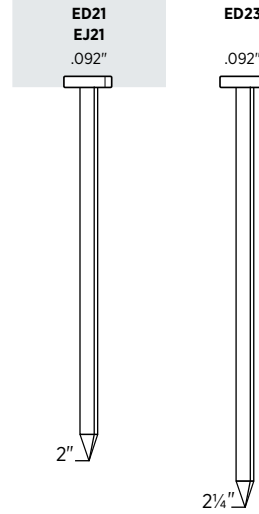

15° Ring Shank Coil Nails

Pallets, crates, fencing, wood shingles, siding and underlayment

Length	Point	Finish	Coating	Collation	Box Count	Item Code
1¼" x .082"	Diamond	Bright	Sencote	Angled flat wire coil	14M	SE15APBH
1½" x .082"	Diamond	Bright	Sencote	Angled flat wire coil	11.2M	SE17APBH
1½" x .092"	Diamond	Exterior	Sencote	Angled flat wire coil	9M	EL17ADBH
1¾" x .092"	Diamond	Hot Dip	Sencote	Angled flat wire coil	3.6M	EL19ASBH
1⅞" x .092"	Diamond	Galv	Sencote	Angled flat wire coil	3.6M	EL20AABH
1⅞" x .092"	Diamond	Hot Dip	Sencote	Angled flat wire coil	3.6M	EL20ASBH
2" x .092"	Diamond	Exterior	Sencote	Angled flat wire coil	9M	EL21ADBH
2" x .092"	Diamond	Hot Dip	Sencote	Angled flat wire coil	3.6M	EL21ASBH
2¼" x .092"	Diamond	Galv	Sencote	Angled flat wire coil	3.6M	EL23AABH
2¼" x .092"	Diamond	Hot Dip	Sencote	Angled flat wire coil	3.6M	EL23ASBH
1¾" x .092"	Diamond	Stainless	Sencote	Angled flat wire coil	3.6M	EL19AGBH
1⅞" x .092"	Diamond	Stainless	Sencote	Angled flat wire coil	3.6M	EL20AGBH
2" x .092"	Diamond	Stainless	Sencote	Angled flat wire coil	3.6M	EL21AGBH
2¼" x .092"	Diamond	Stainless	Sencote	Angled flat wire coil	3.6M	EL23AGBH



PAL57XP

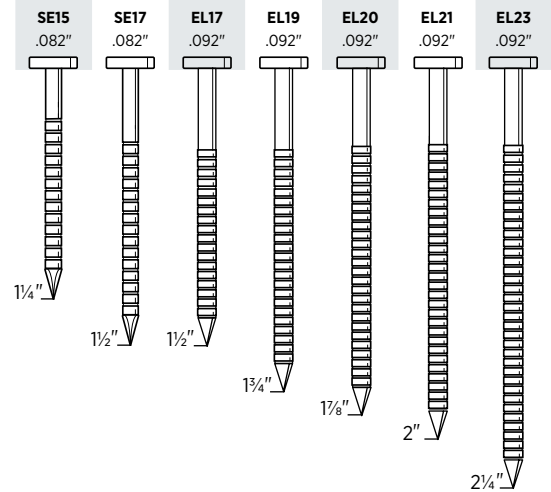

PALLETS & CRATING FASTENERS

15° Smooth-Shank Coil Nails

Pallets, framing, sheathing, subfloor, decks and trusses						
Length	Point	Finish	Coating	Collation	Box Count	Item Code
2" x .113"	Diamond	Bright	Sencote	Angled flat wire coil	6M	GD21APBF
2 3/8" x .113"	Diamond	Bright	Sencote	Angled flat wire coil	6M	GD24APBF
2 1/2" x .113"	Diamond	Bright	Sencote	Angled flat wire coil	6M	GD25APBF
2 1/2" x .131"	Diamond	Bright	Sencote	Angled flat wire coil	3.6M	KD25APBF
3" x .120"	Diamond	Bright	Sencote	Angled flat wire coil	4M	HD27APBF
3" x .131"	Diamond	Bright	Sencote	Angled flat wire coil	3.6M	KD27APBF
3 1/4" x .120"	Diamond	Bright	Sencote	Angled flat wire coil	4M	HD28APBF
3 1/4" x .131"	Diamond	Bright	Sencote	Angled flat wire coil	3.6M	KD28APBF
3 1/2" x .131"	Diamond	Bright	Sencote	Angled flat wire coil	3.6M	KD29APBF
5" x .148"	Diamond	Bright	Sencote	Angled flat wire coil	1.8M	MD34APBF
2" x .113"	Diamond	Galv	Sencote	Angled flat wire coil	6M	GD21AABF
2 1/2" x .113"	Diamond	Galv	Sencote	Angled flat wire coil	6M	GD25AABF
3" x .131"	Diamond	Galv	Sencote	Angled flat wire coil	3.6M	KD27AABF
3" x .131"	Diamond	Hot Dip	Sencote	Angled flat wire coil	2.4M	KD27ASBF
3 1/4" x .131"	Diamond	Galv	Sencote	Angled flat wire coil	3.6M	KD28AABF
3 1/4" x .131"	Diamond	Hot Dip	Sencote	Angled flat wire coil	2.4M	KD28ASBF

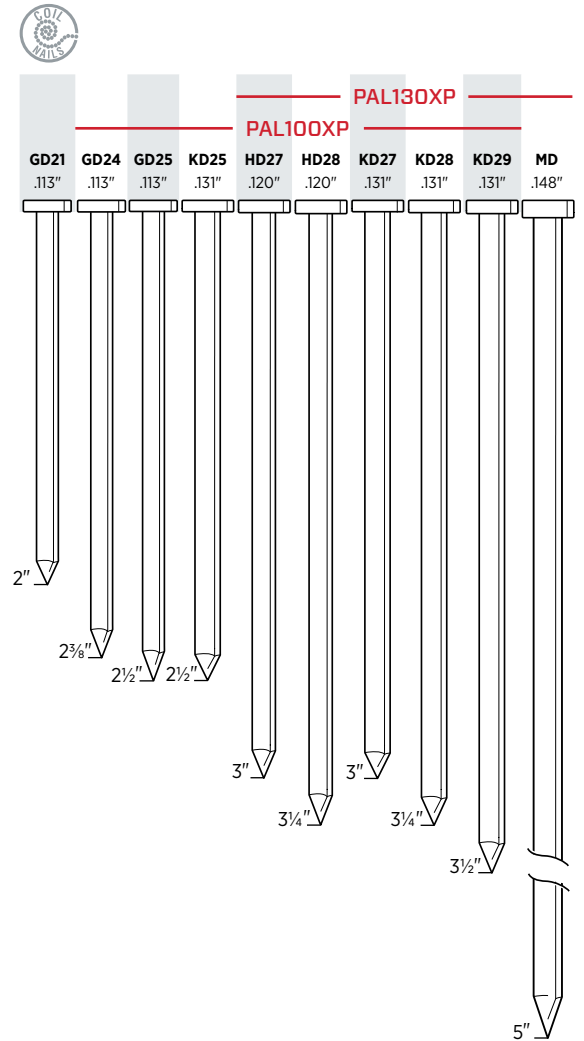

15° Ring-Shank Coil Nails

Pallets, framing, sheathing, subfloor, decks and trusses						
Length	Point	Finish	Coating	Collation	Box Count	Item Code
2" x .099"	Diamond	Bright	Sencote	Angled flat wire coil	6.6M	BL21APBF
2" x .099"	Diamond	Bright	Sencote	Angled flat wire coil	6.6M	BT21APBF
2" x .113"	Diamond	Bright	Sencote	Angled flat wire coil	6M	GL21APBF
2 1/4" x .099"	Diamond	Bright	Sencote	Angled flat wire coil	6.6M	BL23APBF
2 3/8" x .113"	Diamond	Bright	Sencote	Angled flat wire coil	6M	GL24APBF
2 1/4" x .099"	Diamond	Galv	Sencote	Angled flat wire coil	6.6M	BE23AABF
2 3/8" x .113"	Diamond	Galv	Sencote	Angled flat wire coil	6M	GL24AABF
2 3/8" x .113"	Diamond	Hot Dip	Sencote	Angled flat wire coil	2.7M	GL24ASBF
3" x .120"	Diamond	Galv	Sencote	Angled flat wire coil	3.6M	HL27AABF
3" x .120"	Diamond	Hot Dip	Sencote	Angled flat wire coil	2.4M	HL27ASBF
2 3/8" x .113"	Diamond	Stainless	Sencote	Angled flat wire coil	2.7M	GL24AGBF
3" x .120"	Diamond	Stainless	Sencote	Angled flat wire coil	2.4M	HL27AGBF

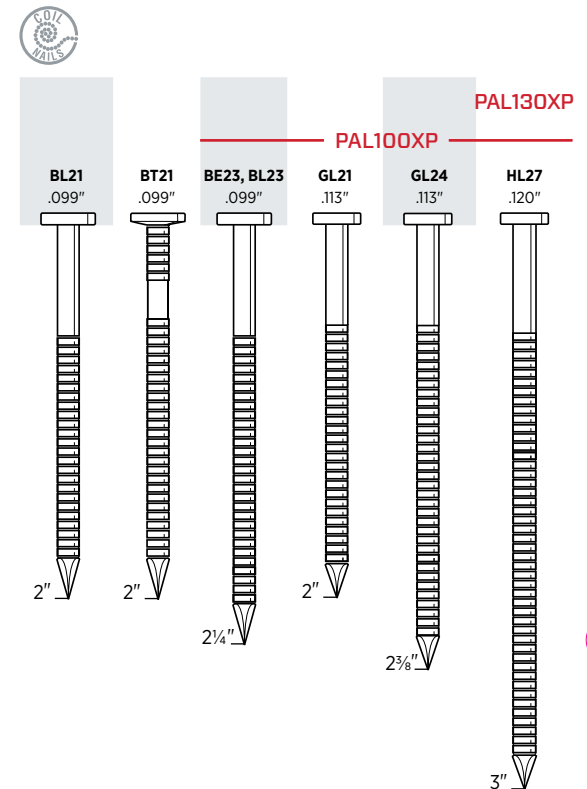

PALLETS & CRATING FASTENERS

15° Screw-Shank Coil Nails

Pallets, framing, sheathing, subfloor, decks and trusses						
Length	Point	Finish	Coating	Collation	Box Count	Item Code
2" x .099"	Blunt Dia.	Bright	Sencote	Angled flat wire coil	9M	BK21BPBFN
2" x .099"	Chisel	Bright	Sencote	Angled flat wire coil	6.6M	BK21EPBF
2¼" x .099"	Blunt Dia.	Bright	Sencote	Angled flat wire coil	9M	BK23BPBFN
2¼" x .099"	Chisel	Bright	Sencote	Angled flat wire coil	6.6M	BK23EPBF
2½" x .099"	Blunt Dia.	Bright	Sencote	Angled flat wire coil	6M	BK25BPBFN
3" x .120"	Diamond	Bright	Sencote	Angled flat wire coil	4M	HK27APBFN

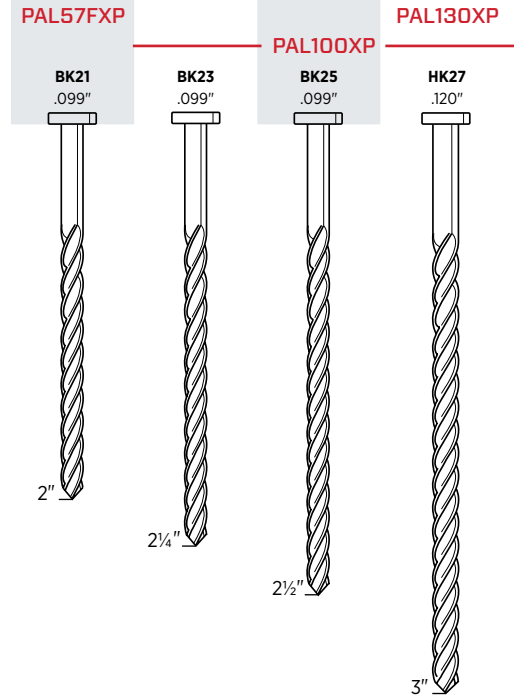

20^{GA} ½" Crown Fine Wire Staples

Packaging, set-up boxes and bedding						
Length	Point	Finish	Coating	Collation	Box Count	Item Code
5/16"	Chisel	Galv	Sencote	Glued Strip	24M	F05BAAP
3/8"	Chisel	Galv	Sencote	Glued Strip	10M	F06BAA
3/8"	Chisel	Galv	Sencote	Glued Strip	24M	F06BAAP
1/2"	Chisel	Galv	Sencote	Glued Strip	10M	F08BAAN
1/2"	Chisel	Galv	Sencote	Glued Strip	15M	F08BAAP
3/8"	Chisel	Stainless	Sencote	Glued Strip	10M	F06BGA
1/2"	Chisel	Stainless	Sencote	Glued Strip	10M	F08BGA

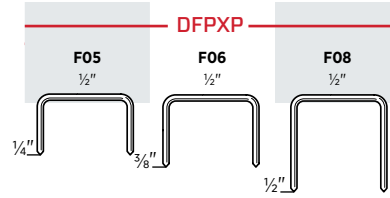

18^{GA} 7/16" Crown Fine Wire Staples

For assembling packaging and joining corrugated materials						
Length	Point	Finish	Coating	Collation	Box Count	Item Code
3/8"	Chisel	Galv	Plain	Glued Strip	5M	J06BAA
1/2"	Chisel	Galv	Plain	Glued Strip	5M	J08BAAN
5/8"	Chisel	Galv	Plain	Glued Strip	5M	J10BAAN

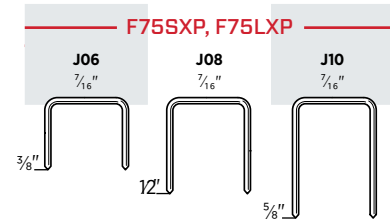

UPHOLSTERY & FURNITURE

SENCO HAS HAD YOU COVERED, SINCE 1948

SENCO offers a range of fine and medium wire staplers for upholstery and furniture assembly. Our upholstery staplers are the most customizable in the industry, with long nosepieces, extended magazines and a wide range of fasteners for any project you face.

APPLICATIONS

Upholstery, furniture assembly, cabinets, bedding, picture frames, molding, roof felt, house wrap, RV construction

FEATURES

- Lightweight
- Ergonomic
- Variety of configurations



SFT10XP FAMILY

3/16", 3/8", 7/16", 1/2" CROWN,
5/8" FINE WIRE STAPLERS

SFT10XP

22_{GA}

20_{GA}



Features

- Heavy-duty steel cap
- Short trigger stroke
- Rear exhaust keeps oil off abric
- Automatic models have adjustable speed triggers

Models and Item Numbers

Crown	Ga	Staple	Description	Item Code
3/16"	22	A/D Wire	Standard	6S0001N
3/16"	22	A/D Wire	Auto	6S0101N
1/2"	22	B Wire	Standard	6S0011N
3/8"	22	C Wire	Standard	6S0021N
3/8"	22	C Wire	Auto	6S0121N
3/16"	20	E Wire	Standard	6S0031N
1/2"	20	F Wire	Standard	6S0041N
3/8"	20	G Wire	Standard	6S0051N

SFT10XP FAMILY

3/16", 3/8", 7/16", 1/2" CROWN,
58" FINE WIRE STAPLERS

DOUBLE LENGTH MAGAZINE

22_{GA}

20_{GA}



Features

- Heavy-duty steel cap
- Short trigger stroke
- Rear exhaust keeps oil off abric
- Automatic models have adjustable speed triggers

Models and Item Numbers

Crown	Ga	Staple	Description	Item Code
1/2"	22	B Wire	Standard	6S0211N
1/2"	22	B Wire	Auto	6S0311N
3/8"	22	C Wire	Standard	6S0221N
3/8"	22	C Wire	Auto	6S0321N
1/2"	20	F Wire	Auto	6S0341N
3/8"	20	G Wire	Standard	6S0251N
3/8"	20	G Wire	Auto	6S0351N
7/16"	20	H Wire	Auto	6S0361N

SFT10XP FAMILY

3/16", 3/8", 7/16", 1/2" CROWN,
58" FINE WIRE STAPLERS

LONG NOSE

22_{GA}



Features

- Heavy-duty steel cap
- Short trigger stroke
- Rear exhaust keeps oil off abric
- Automatic models have adjustable speed triggers

Models and Item Numbers

Crown	Ga	Staple	Description	Item Code
3/8"	22	C Wire	Standard	6S0421N

Product Reference Chart

TOOL SPECS	SFT10XP
Trigger	Sequential, Auto
Op. Pressure	60-95 psi (4.1-6.5 bar)
Air Consumption (60CPM)	.77 scfm
Air Inlet	1/4" NPT
Weight	2.1 lbs (0.955 kg)
Height	6.57" (167 mm)
Length	8.58" (218 mm)
Width	1.65" (42 mm)
Main Body Material	Aluminum
Warranty	5 yrs
FASTENER SPECS	are located on pages 61-63
Capacity	110-192
Range	5/32" - 5/8"
Crown	3/16", 3/8", 7/16", 1/2"
Gauge/Collation	22 Ga., 20 Ga. Straight Glued Strip
Series	A, B, C, D, E, F, G, H



Stapling Upholstery for Over 60 Years.

SENCO® offers 18 configurations of upholstery staplers and over 40 combinations of staple length, crown and gauge.

SFW09

3/8" CROWN, 5/8" FINE WIRE STAPLER

ITEM# 4C0001N

22_{GA}



Features

- Rear exhaust keeps oil off fabric
- Full 1" lip length
- Rear magazine bumper protects fabric
- Rounded steel cap won't snag fabric

SNS200XP-BST

7/16" CROWN, HEAVY WIRE STAPLER

ITEM# 7C0001N

17_{GA}

16_{GA}



Features

- Innovative magazine-removal mechanism maintains a clean, narrow line of sight for precise staple placement
- 1" lip length allows access to tight corners
- Durable all-metal magazine construction
- Precision-machined drive track ensures accurate, jam-free staple drives

The SNS200XP-BST is the Benchmark Stapler for the Furniture Industry.

- 20% more powerful than all other staplers in its class to handle the toughest engineered woods.
- Drives both 16 and 17 gauge, 7/16" crown staples (1" to 2" in length).
- Combination of class-leading power, durability and ergonomics makes it an unrivaled professional tool.



Product Reference Chart

TOOL SPECS	SFW09	SNS200XP-BST
Trigger	Dual	Contact
Op. Pressure	60-95 psi (4.1-6.5 bar)	70-120 psi (4.8-8.3 bar)
Air Consumption	.77 scfm	5.52 scfm
Air Inlet	1/4" NPT	3/8" NPT
Weight	2.1 lbs (0.955 kg)	5.9 lbs (2.67 kg)
Height	6" (152 mm)	11" (279 mm)
Length	9.25" (235 mm)	14" (356 mm)
Width	1.63" (41 mm)	4" (102 mm)
Main Body Material	Aluminum	Aluminum
Warranty	5 yrs	5 yrs
FASTENER SPECS	are located on pages 61-63	
Capacity	110 - 168	160
Range	5/32" - 5/8"	1" - 2"
Crown	3/8"	7/16"
Gauge/Collation	22 Ga. Straight Glued Strip	17 Ga. (O-Wire), 16 Ga. (N-Wire) Straight Glued/Taped Strip
Series	C	N, O

UPHOLSTERY & FURNITURE FASTENERS

22^{GA}

3/16" Crown Fine Wire Staples

Furniture upholstery, felt, insulation, casebacks, screening and shoes						
Length	Point	Finish	Coating	Collation	Box Count	Item Code
1/4"	Chisel	Galv	Sencote	Straight Glued Strip	10M	A04BAAN
3/8"	Chisel	Galv	Sencote	Straight Glued Strip	30M	A06BABN
3/8"	Chisel	Galv	Sencote	Straight Glued Strip	40M	A06BABP
1/2"	Chisel	Galv	Sencote	Straight Glued Strip	20M	A08BAB
1/2"	Chisel	Galv	Sencote	Straight Glued Strip	30M	A08BABP
5/8"	Chisel	Galv	Sencote	Straight Glued Strip	20M	D10BABN
5/8"	Chisel	Galv	Sencote	Straight Glued Strip	23M	D10BABPN

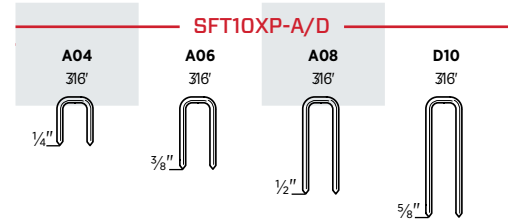

22^{GA}

1/2" Crown Fine Wire Staples

Furniture upholstery, felt, insulation, casebacks, screening and shoes						
Length	Point	Finish	Coating	Collation	Box Count	Item Code
1/4"	Chisel	Galv	Plain	Straight Glued Strip	25M	B04BAAPN
5/16"	Chisel	Galv	Plain	Straight Glued Strip	45M	B05BAAP
5/16"	Outside Chisel	Galv	Plain	Straight Glued Strip	9M	B05DAA
3/8"	Chisel	Galv	Plain	Straight Glued Strip	40M	B06BAAP
1/2"	Chisel	Galv	Plain	Straight Glued Strip	25M	B08BAAP

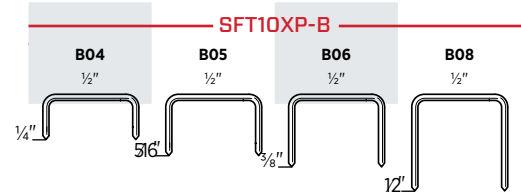

22^{GA}

3/8" Crown Fine Wire Staples

Furniture upholstery, felt, insulation, casebacks, screening and shoes						
Length	Point	Finish	Coating	Collation	Box Count	Item Code
532	Chisel	Galv	Plain	Straight Glued Strip	60M	C02BAAPN
3/16"	Chisel	Galv	Plain	Straight Glued Strip	55M	C03BAAPN
1/4"	Chisel	Galv	Plain	Straight Glued Strip	35M	C04BAAP
5/16"	Chisel	Galv	Plain	Straight Glued Strip	28M	C05BAAPN
3/8"	Chisel	Galv	Plain	Straight Glued Strip	50M	C06BAAP
7/16"	Chisel	Galv	Plain	Straight Glued Strip	40M	C07BAAPN
1/2"	Chisel	Galv	Plain	Straight Glued Strip	35M	C08BAAP
5/8"	Chisel	Galv	Plain	Straight Glued Strip	27M	C10BAAP
3/16"	Chisel	Stainless	Plain	Straight Glued Strip	25M	C03BGAN
1/4"	Chisel	Stainless	Plain	Straight Glued Strip	25M	C04BGAN
3/8"	Chisel	Stainless*	Plain	Straight Glued Strip	10M	C06BHA
3/8"	Chisel	Stainless	Plain	Straight Glued Strip	10M	C06BGA

*High-Tensile Stainless Steel AISI-304

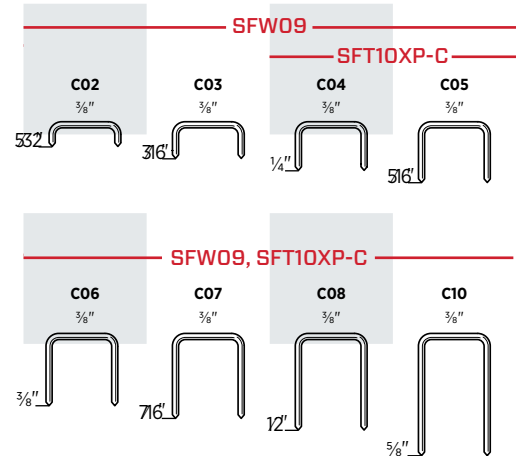

21^{GA}

3/16" Crown Fine Wire Staples

Furniture upholstery, felt, insulation, casebacks, screening and shoes						
Length	Point	Finish	Coating	Collation	Box Count	Item Code
5/8"	Chisel	Galv	Sencote	Straight Glued Strip	10M	W10BAB
3/4"	Chisel	Galv	Sencote	Straight Glued Strip	10M	W11BABN

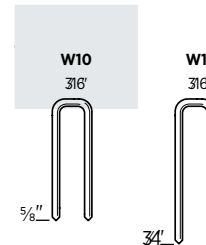

UPHOLSTERY & FURNITURE FASTENERS

20^{GA}

3/16" Crown Fine Wire Staples

Furniture upholstery, felt, insulation, casebacks, screening and shoes						
Length	Point	Finish	Coating	Collation	Box Count	Item Code
3/8"	Chisel	Galv	Plain	Straight Glued Strip	10M	E06BAA
1/2"	Chisel	Galv	Plain	Straight Glued Strip	10M	E08BAA
5/8"	Chisel	Galv	Plain	Straight Glued Strip	5M	E10BAA

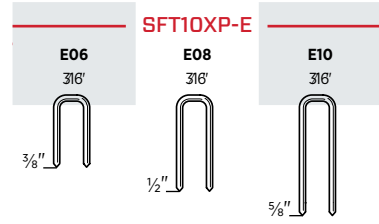

20^{GA}

1/2" Crown Fine Wire Staples

Upholstery, felt, insulation and casebacks						
Length	Point	Finish	Coating	Collation	Box Count	Item Code
1/4"	Chisel	Galv	Plain	Straight Glued Strip	10M	F04BAAN
1/4"	Chisel	Galv	Plain	Straight Glued Strip	17M	F04BAAP
5/16"	Chisel	Galv	Plain	Straight Glued Strip	24M	F05BAAP
3/8"	Chisel	Galv	Plain	Straight Glued Strip	10M	F06BAA
3/8"	Chisel	Galv	Plain	Straight Glued Strip	24M	F06BAAP
1/2"	Chisel	Galv	Plain	Straight Glued Strip	10M	F08BAAN
1/2"	Chisel	Galv	Plain	Straight Glued Strip	15M	F08BAAP
3/8"	Chisel	Stainless	Plain	Straight Glued Strip	10M	F06BGA
1/2"	Chisel	Stainless	Plain	Straight Glued Strip	10M	F08BGA

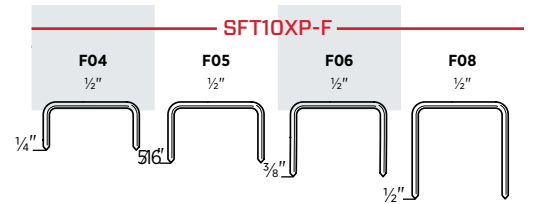

20^{GA}

3/8" Crown Fine Wire Staples

Upholstery, felt, insulation and casebacks						
Length	Point	Finish	Coating	Collation	Box Count	Item Code
1/4"	Chisel	Galv	Plain	Straight Glued Strip	10M	G04BAAN
3/8"	Chisel	Galv	Plain	Straight Glued Strip	5M	G06BABN
1/2"	Chisel	Galv	Plain	Straight Glued Strip	5M	G08BAB
5/8"	Chisel	Galv	Plain	Straight Glued Strip	5M	G10BAB

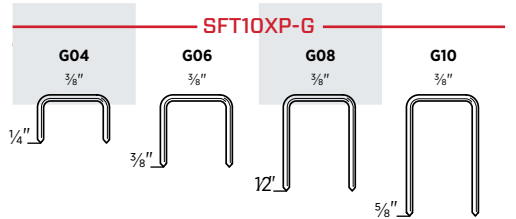

20^{GA}

7/16" Crown Fine Wire Staples

Upholstery, felt, insulation and casebacks						
Length	Point	Finish	Coating	Collation	Box Count	Item Code
3/8"	Chisel	Galv	Plain	Straight Glued Strip	5M	H06BAA



17^{GA}

7/16" Crown Heavy Wire Staples*

Furniture frames and crates						
Length	Point	Finish	Coating	Collation	Box Count	Item Code
1/4"	Chisel	Bright	Sencote	Glued	10M	O15BRBB
1/8"	Chisel	Bright	Sencote	Glued	10M	O16BRBB
1/2"	Chisel	Bright	Sencote	Glued	10M	O17BRBB
1 5/8"	Chisel	Bright	Sencote	Glued	10M	O18BRBB
1 3/4"	Chisel	Bright	Sencote	Glued	10M	O19BRBB

*Drives only from SNS44XP and SNS45XP staplers manufactured after 05/2010, and SNS41 manufactured after 09/2010. For older tools, order upgrade kits: SNS41-YK0794, SNS44-YK0793, SNS45-FA0186.

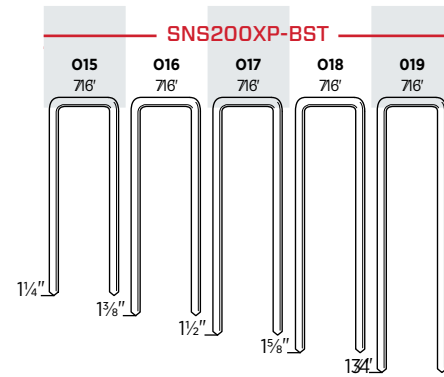

16^{GA}

7/16" Crown Heavy Wire Staples

Cabinets, casebacks, drawers and upholstery						
Length	Point	Finish	Coating	Collation	Box Count	Item Code
3/4"	Chisel	Bright	Sencote	Glued	5M	N11BRB
1"	Chisel	Bright	Sencote	Glued	5M	N13BRB
1 1/8"	Chisel	Bright	Sencote	Tape	10M	N14BRB
1 1/4"	Chisel	Bright	Sencote	Tape	10M	N15BRB
1 3/8"	Chisel	Bright	Sencote	Tape	10M	N16BRB
1 3/8"	Step	Bright	Sencote	Glued	10M	N16RRB
1 1/2"	Chisel	Bright	Sencote	Tape	10M	N17BRB
1 5/8"	Chisel	Bright	Sencote	Tape	10M	N18BRB
1 3/4"	Chisel	Bright	Sencote	Tape	10M	N19BRB
2"	Chisel	Bright	Sencote	Tape	10M	N21BRB
1/2"	Chisel	Galv	Sencote	Glued	5M	N08BABN
1/2"	Chisel	Galv*	Sencote	Glued	5M	N08BBBN
1/2"	Diverg	Galv*	Sencote	Glued	5M	N08FBB
5/8"	Chisel	Galv	Sencote	Glued	5M	N10BAB
3/4"	Chisel	Galv	Sencote	Glued	5M	N11BAB
3/4"	Diverg	Galv*	Sencote	Glued	5M	N11FBB
7/8"	Chisel	Galv	Sencote	Glued	5M	N12BABN
7/8"	Diverg	Galv	Sencote	Glued	5M	N12FABN
1"	Chisel	Galv	Sencote	Glued	5M	N13BAB
1"	Diverg	Galv	Sencote	Glued	5M	N13FAB
1 1/8"	Chisel	Galv	Sencote	Tape	10M	N14BAB
1 1/8"	Diverg	Galv	Sencote	Glued	10M	N14FAB
1 1/4"	Chisel	Galv	Sencote	Tape	10M	N15BAB
1 1/4"	Diverg	Galv	Sencote	Glued	10M	N15FAB
1 3/8"	Chisel	Galv	Sencote	Tape	10M	N16BAB
1 1/2"	Chisel	Galv	Sencote	Tape	10M	N17BAB
1 1/2"	Chisel	Galv	Sencote	Glued	10M	N17BPE
1 5/8"	Chisel	Galv	Sencote	Glued	10M	N18BAB
1 3/4"	Chisel	Galv	Sencote	Tape	10M	N19BAB
1 3/4"	Chisel	Galv	Sencote	Glued	10M	N19BPE
2"	Chisel	Galv	Sencote	Tape	10M	N21BAB
2"	Chisel	Galv	Sencote	Glued	10M	N21BPE
1 1/4"	Chisel	Stainless	Sencote	Glued	3M	N15BGB
1 1/2"	Chisel	Stainless	Sencote	Glued	3M	N17BGB
1 3/4"	Chisel	Stainless	Sencote	Glued	3M	N19BGBN
2"	Chisel	Stainless	Sencote	Glued	3M	N21BGBN

*High-Tensile Galvanized

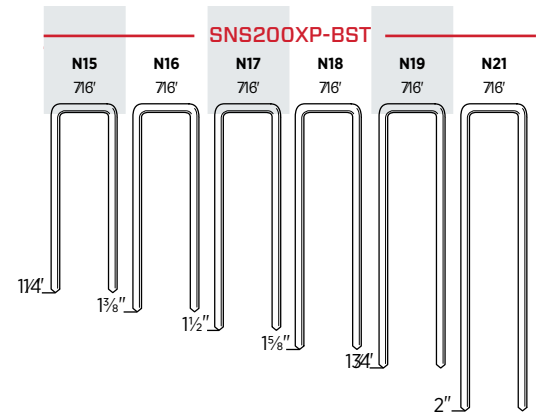
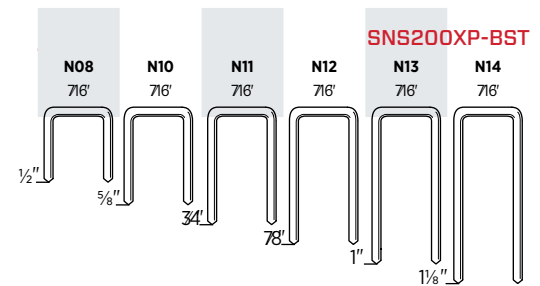

FLOORING

HARDWOOD FLOORING DONE RIGHT

Hardwood floors aren't so hard to install with our SHF200 and SHFS200 stand-up flooring tools. With long, ergonomic handles and bases that easily adjust to any floor thickness, you will get the jobs done in no time. SENCO is committed to creating industry-leading flooring tools to make your job easier.



SHF200

2" PNEUMATIC Mallet-Actuated
Hardwood Flooring Cleat Nailer
ITEM# 8D0001N

16_{GA}



Features

- Innovative non-marring base that adjusts between 1/2" and 3/4" flooring without the use of tools
- Safety trigger prevents accidental ejection of fasteners
- Lightweight and well-balanced yet 5% more powerful than competitive flooring nailers
- Extra-long ergonomic handle reduces the amount the operator has to bend over

SHFS200

2" PNEUMATIC Mallet-Actuated
Hardwood Flooring Stapler
ITEM# 8D0002N

15.5_{GA}



Features

- Innovative non-marring base that adjusts between 1/2" and 3/4" flooring without the use of tools
- Safety trigger prevents accidental ejection of fasteners
- Lightweight and well-balanced yet 5% more powerful than competitive flooring nailers
- Extra-long ergonomic handle reduces the amount the operator has to bend over

SLS20XP-HF

3/8" Crown, 1" Hardwood &
Laminate Floor Stapler
ITEM# 490021N

19_{GA}



Features

- Never-Lube® design — No oil required
- Front block easily adjusts to floor thickness
- Industry-exclusive safety controls staple placement
- Power-adjusted motor drives staples to consistent and controllable depth

Product Reference Chart

TOOL SPECS	SHF200	SHFS200	SLS20XP-HF
Trigger	Sequential	Sequential	Sequential
Op. Pressure	90-110 psi (6.2-7.6 bar)	90-110 psi (6.2-7.6 bar)	70- 20 psi (4.8-8.3 bar)
Air Consumption (60 CPM)	2.52 scfm	2.52 scfm	1.92 scfm
Air Inlet	1/4" NPT	1/4" NPT	1/4" NPT
Weight	10.1 lbs (4.58 kg)	11.1 lbs (5.0 kg)	3.2 lbs (1.5 kg)
Height	21.5" (546 mm)	21.5" (546 mm)	9" (228 mm)
Length	17.8" (452 mm)	17.8" (452 mm)	13" (332 mm)
Width	3.1" (78 mm)	3.1" (78 mm)	3" (76 mm)
Main Body Material	Aluminum	Aluminum	Aluminum
Warranty	5 yrs	5 yrs	5 yrs
FASTENER SPECS	Fasteners are located on page 66		
Capacity	107	102	168
Range	1 1/2"-2"	1"-2"	5/8"-1"
Type	L-Type Cleat Nails Glued Strip	Straight Glued Strip	Straight Glued Strip
Series	RW	FL	R
FLOORING MATERIAL			
Hardwood	Yes	Yes	Yes
Hardwood Laminate	Yes	Yes	Yes
Board Thickness	1/2"-3/4" (12-19 mm)	1/2"-3/4" (12-19 mm)	1/4", 5/16", and 3/8"

16^{GA}

L-Head Flooring Cleat Nails

1/2" - 33/32" hardwood flooring

Length	Point	Finish	Coating	Collation	Box Count	Item Code
1 1/2"	Blunt Diamond	Bright	N/A	Straight Glued Strip	1M	RW17BPE
1 3/4"	Blunt Diamond	Bright	N/A	Straight Glued Strip	1M	RW19BPE
2"	Blunt Diamond	Bright	N/A	Straight Glued Strip	1M	RW21BPE
2"	Blunt Diamond	Stainless	N/A	Straight Glued Strip	1M	RW21BGE

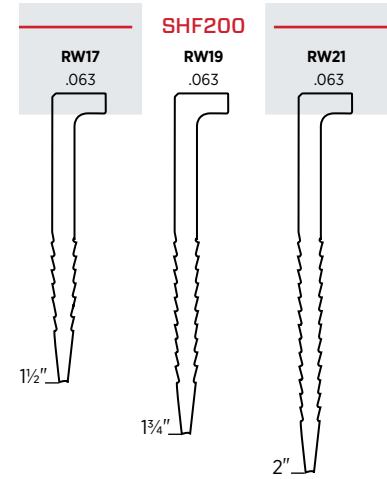

15.5^{GA}

1/2" Crown Flooring Staples

1/2" - 3/4" hardwood flooring

Length	Point	Finish	Coating	Collation	Box Count	Item Code
1 1/2"	Chisel	Galv	Sencote	Glued Strip	5.2M	FL17BAB
1 3/4"	Chisel	Galv	Sencote	Glued Strip	5.2M	FL19BAB
2"	Chisel	Galv	Sencote	Glued Strip	5.2M	FL21BAB

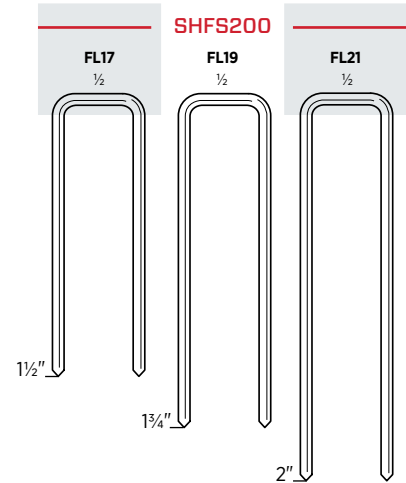

19^{GA}

3/16" Crown Hardwood Flooring Staples

1/4", 5/16", and 3/8" hardwood and hardwood laminate floors.

Length	Point	Finish	Coating	Collation	Box Count	Item Code
5/8"	Chisel	Galv	Sencote	Straight Glued Strip	5M	R10BAB
3/4"	Chisel	Galv	Sencote	Straight Glued Strip	5M	R11BAB
1"	Chisel	Galv	Sencote	Straight Glued Strip	5M	R13BAB

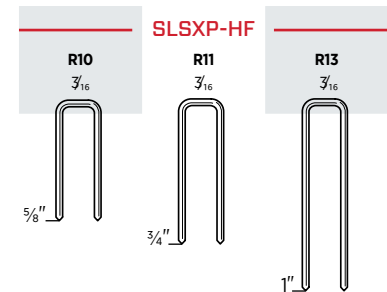

BOX, CARTON & PALLET CONVERSION FASTENERS

Nails

Boxes Per Carton	Cartons Per Pallet	Boxes Per Pallet	Item Code	Boxes Per Carton	Cartons Per Pallet	Boxes Per Pallet	Item Code	Boxes Per Carton	Cartons Per Pallet	Boxes Per Pallet	Item Code
5	180	900	A100509	na	na	140	CZ10EAAAN	na	na	40	GD24APBF
5	180	900	A100629	na	na	140	CZ11EAAAN	na	na	45	GD24ASBS
5	180	900	A100759	5	40	200	DA13EPBN	na	na	40	GD25AABF
5	180	900	A101009	5	40	200	DA15AIA	na	na	48	GD25AABSN
5	180	900	A101259	5	40	200	DA15EABN	na	na	40	GD25APBF
5	180	900	A101379	5	40	200	DA15EPBN	na	na	72	GE21APAX
5	180	900	A101509	5	40	200	DA17AIA	na	na	72	GE24AGBX
5	180	900	A102009	5	40	200	DA17EABN	na	na	72	GE24APBX
5	180	900	A109809	5	40	200	DA17EPBN	na	na	72	GE24ASBX
5	180	900	A109909	4	40	160	DA19AIA	na	na	40	GL21APBF
5	140	700	A201009	4	40	160	DA19EABN	na	na	45	GL21ASBS
5	140	700	A201257	4	40	160	DA19EPBN	na	na	40	GL24AABF
5	140	700	A201259	4	40	160	DA21EABN	na	na	48	GL24AABSN
5	140	700	A201509	na	na	90	DA21EGBN	na	na	24	GL24AGBF
5	140	700	A202009	4	40	160	DA21EPBN	na	na	72	GL24AGBS
5	140	700	A209809	3	72	216	DA23EPB	na	na	40	GL24APBF
5	140	700	A209909	3	40	120	DA23EPBN	na	na	120	GL24ASBSR
5	96	480	A301500	na	na	80	DA25EGB	na	na	48	H527APBXN
5	96	480	A301750	3	40	120	DA25EPB	na	na	80	H527APBXR
5	96	480	A302000	3	40	120	DA25EAB	na	na	48	H527ASBXN
5	96	480	A302009	na	na	24	ED19ASBC	na	na	48	H528APBXN
5	96	480	A302500	na	na	60	ED21AABH	na	na	48	H627APBXN
5	96	480	A302509	na	na	60	ED21ADBH	na	na	48	H627ASBXN
5	96	480	A401009	na	na	60	ED23AABH	na	na	80	H627ASBXR
5	96	480	A401259	na	na	24	ED23ASBC	na	na	48	HC27APBX
5	96	480	A401509	na	na	60	ED23ADBH	na	na	48	HC27ASBX
5	96	480	A401759	na	na	40	EJ21ADBH	na	na	48	HC28APBX
5	96	480	A402009	na	na	24	EJ21ASBC	na	na	40	HD27APBF
5	96	480	A402509	na	na	40	EJ23AABF	na	na	48	HD27APBSN
5	96	480	A409809	na	na	40	EJ23ADBCH	na	na	40	HD28APBF
24	30	720	AX10EAA	na	na	40	EJ23ADBH	na	na	48	HE27ASBX
20	30	600	AX11EAA	na	na	24	EJ23ASBC	na	na	80	HF27ABK
16	30	480	AX13EAA	na	na	42	EL17ADBH	na	na	80	HF27EPAX
5	140	700	AX13EGAR	na	na	24	EL19ASBC	na	na	80	HF27EDB
12	30	360	AX15EAA	na	na	60	EL19ASBH	na	na	45	HJ25ADBS
5	140	700	AX15EGAR	na	na	60	EL20AABH	na	na	35	HK27APBFN
10	30	300	AX17EAA	na	na	60	EL20ASBH	na	na	40	HL27AABF
5	140	700	AX17EGAR	na	na	42	EL21ADBH	na	na	48	HL27AABSN
10	30	300	AX18EAA	na	na	60	EL21AGBH	na	na	24	HL27AGBF
8	30	240	AX19EAA	na	na	60	EL21ASBH	na	na	54	HL27AGBS
5	140	700	AX21EGAR	na	na	60	EL23AABH	na	na	24	HL27ASBF
6	30	180	AX21EAAAN	na	na	60	EL23AGBH	na	na	40	HL27ASBS
6	30	180	AX22EAAAN	na	na	24	EL23ASBC	na	na	40	HR22APAF
24	30	720	AY10EAA	na	na	60	EL23ASBH	na	na	40	HR74APAF
20	30	600	AY11EAA	na	na	80	G521APBXN	na	na	72	K525APBXN
16	30	480	AY13EAA	na	na	80	G521ASBXN	na	na	48	K527APBXN
32	30	960	AZ08EAA	na	na	72	G524APBXN	na	na	80	K527APBXR
24	30	720	AZ11EAA	na	na	72	G524ASBXN	na	na	48	K527ASBXN
16	30	480	AZ13EAA	na	na	80	G621APBXN	na	na	48	K528APBXN
na	na	30	BD17APBC	na	na	80	G621ASBXN	na	na	80	K528APBXR
na	na	45	BE23AABF	na	na	72	G624APBXN	na	na	48	K528ASBXN
na	na	40	BG17AAA	na	na	72	G624ASBXN	na	na	48	K529APBXN
na	na	40	BG17AAAQ	na	na	80	GC21APBX	na	na	48	K529ASBXN
na	na	40	BG18AAA	na	na	80	GC23AHAK	na	na	48	K627ASBXN
na	na	40	BG18AAAQ	na	na	72	GC23APBX	na	na	48	K628APBXN
na	na	35	BK21BPBFN	na	na	72	GC24APBX	na	na	48	K628ASBXN
na	na	45	BK21EPBF	na	na	72	GC24ASBX	na	na	48	K629ASBXN
na	na	35	BK23BPBFN	na	na	72	GC25AABX	na	na	80	KC27AGBK
na	na	45	BK23EPBF	na	na	72	GC25APBX	na	na	48	KC27APBX
na	na	35	BK25BPBFN	na	na	40	GD21AABF	na	na	64	KC28AGBK
na	na	45	BL21APBF	na	na	48	GD21AABSN	na	na	48	KC28APBX
na	na	45	BL23APBF	na	na	40	GD21APBF	na	na	48	KC28ASBX
na	na	45	BT21APBF	na	na	48	GD21APBSN	na	na	48	KC29APBX
na	na	140	CZ08EAAAN	na	na	45	GD23AHAS	na	na	48	KC29ASBX

*na indicates not packed in cartons – available in boxes or skids only

BOX, CARTON & PALLET CONVERSION FASTENERS

Nails — continued

Boxes Per Carton	Cartons Per Pallet	Boxes Per Pallet	Item Code
na	na	48	KC29ASBX
na	na	40	KC31APBX
na	na	40	KD25APBF
na	na	48	KD25APBSN
na	na	40	KD27AABF
na	na	45	KD27AABS
na	na	48	KD27AABSN
na	na	40	KD27APBF
na	na	48	KD27APBSN
na	na	90	KD27APBSR
na	na	24	KD27ASBF
na	na	40	KD27ASBS
na	na	90	KD27ASBSR
na	na	40	KD28AABF
na	na	54	KD28AGBS
na	na	40	KD28APBF
na	na	48	KD28APBSN
na	na	90	KD28APBSR
na	na	24	KD28ASBF
na	na	40	KD28ASBS
na	na	90	KD28ASBSR
na	na	48	KD29AABSN
na	na	40	KD29APBF
na	na	48	KD29APBSN
na	na	40	KD29ASBS
na	na	100	KJ17AEBD
na	na	100	KJ17AHBD
na	na	100	KJ25AEBD
na	na	100	KJ25AHBD
20.0	48	960	M001000
16.0	48	768	M001001
16.0	48	768	M001002
12.0	48	576	M001003
5	96	480	M001003GR
12	48	576	M001004
12	48	576	M001005
5	96	480	M001005GR
12	48	576	M001007
5	96	480	M001007GR
na	na	45	M002038
na	na	45	M002041
na	na	45	M002042
na	na	40	M002101
na	na	40	M002105
na	na	100	M002261
na	na	100	M002262
na	na	100	M002263
na	na	100	M002264
na	na	100	M002265
na	na	100	M002266
na	na	100	M002267
na	na	100	M002268
na	na	24	M003011
na	na	24	M003012
na	na	56	M003101
na	na	56	M003102
na	na	56	M003103
na	na	48	M003104
na	na	40	M003105
na	na	40	M003106
na	na	100	MD17AEBD
na	na	60	MD17AHAD
na	na	48	MD23APBSN

Boxes Per Carton	Cartons Per Pallet	Boxes Per Pallet	Item Code
na	na	100	MD25AEBD
na	na	100	MD25AHBD
na	na	36	MD27APBSN
na	na	36	MD28APBSN
na	na	40	MD34APBF
na	na	100	ND25AEBD
na	na	100	ND25AHBD
12	60	720	RH15EAA
12	60	720	RH17EAA
12	60	720	RH19EAA
12	60	720	RH21EAA
na	na	45	RH25EAA
10	51	510	RW17BPE
10	51	510	RW19BPE
10	51	510	RW21BGE
10	51	510	RW21BPE
2	51	102	RW21BPEP
na	na	40	SC19APB
na	na	40	SC21APB
na	na	45	SE12ADB
na	na	40	SE12BDB
na	na	40	SE15APB
na	na	40	SE15APBH
na	na	40	SE17APB
na	na	40	SE17APBH
na	na	40	SE19APB
na	na	40	SE19APBH
12	60	720	ZX10EAA
5	140	700	ZX10EAANR
12	48	576	ZX13EAA
5	140	700	ZX13EAANR
12	36	432	ZX16EAA
5	140	700	ZX16EAANR
12	36	432	ZX18EAA
5	140	700	ZX18EAANR
10	24	240	ZX21EAA
5	140	700	ZX21EAANR
na	na	50	W3050YXS
5	50	250	W3075PXC
5	50	250	W3075YXC
5	50	250	W3100YXC
na	na	50	W3125YXC

Staples

Boxes Per Carton	Cartons Per Pallet	Boxes Per Pallet	Item Code
48	24	1152	A04BAAN
6	36	216	A06BABN
8	24	192	A06BABP
12	24	288	A08BAB
8	24	192	A08BABP
8	24	192	B04BAAPN
4	24	96	B05BAAP
20	24	480	B05DAA
4	24	96	B06BAAP
4	24	96	B08BAAP
8	24	192	C02BAAPN
8	24	192	C03BGAN
8	24	192	C04BAAP
8	34	272	C04BGAN
8	24	192	C05BAAPN
4	24	96	C06BAAP

Boxes Per Carton	Cartons Per Pallet	Boxes Per Pallet	Item Code
20	32	640	C06BGA
20	32	640	C06BHA
4	24	96	C07BAAPN
4	24	96	C08BAAP
4	24	96	C10BAAP
6	36	216	D10BABN
8	24	192	D10BABPN
20	32	640	E06BAA
16	32	512	E08BAA
25	32	800	E10BAA
12	32	384	F04BAAN
8	24	192	F04BAAP
4	24	96	F05BAAP
10	30	300	F06BAA
4	24	96	F06BAAP
10	24	240	F06BGA
8	30	240	F08BAAN
4	24	96	F08BAAP
8	24	192	F08BGA
10	3	30	F08FAB
8	30	240	F08GAB
na	na	48	FL17BAB
na	na	40	FL19BAB
na	na	40	FL21BAB
24	20	480	G04BAAN
25	32	800	G06BABN
20	32	640	G08BAB
20	20	400	G10BAB
20	24	480	H06BAA
15	16	240	J06BAA
9	32	288	J08BAAN
8	20	160	J10BAAN
8	36	288	K08BABN
9	32	288	K10BABN
6	40	240	K11BAB
10	40	400	K12BAB
12	32	384	K13BABN
10	36	360	L06BAB
na	na	112	L07BABP
na	na	112	L07QBPP
8	36	288	L08BAB
16	36	576	L08BABN
12	36	432	L10BABN
12	36	432	L10BHA
12	36	432	L10HABN
10	36	360	L11BAB
10	36	360	L11BGA
10	36	360	L11BRB
10	36	360	L11HAB
12	36	432	L11HBB
10	36	360	L12BAB
10	36	360	L12QB
8	36	288	L13BABN
8	36	288	L13BRBN
8	36	288	L13HABN
6	36	216	L14BAB
6	36	216	L14BGA
6	36	216	L14BRB
6	36	216	L15BAB
6	36	216	L15BRB
6	36	216	L17BAB
na	na	192	M004092
7	32	224	M06BABN

*na indicates not packed in cartons — available in boxes or skids only

BOX, CARTON & PALLET CONVERSION FASTENERS

Staples — continued

Boxes Per Carton	Cartons Per Pallet	Boxes Per Pallet	Item Code
6	32	192	M08BAB
9	32	288	M10BABN
9	32	288	M10BRBN
8	32	256	M11BABN
8	32	256	M11BRBN
6	32	192	M12BAB
6	32	192	M13BAB
6	32	192	M13BRB
na	na	60	M15BAB
na	na	48	M17BAB
6	32	192	N08BABN
6	32	192	N08BBBN
6	32	192	N08FBB
6	32	192	N11BAB
6	32	192	N11BRB
6	32	192	N11FBB
6	32	192	N12BABN
5	32	160	N12FABN
4	32	128	N13BAB
4	32	128	N13BRB
4	32	128	N13FAB
na	na	56	N14BAB
na	na	56	N14BRB
na	na	56	N14FAB
na	na	56	N15BAB
na	na	56	N15BGB
na	na	56	N15BRB
na	na	56	N15FAB
na	na	56	N16BAB
na	na	56	N16BRB
na	na	56	N16RRB
na	na	48	N17BAB
na	na	165	N17BGB
na	na	48	N17BPE
na	na	48	N17BRB
na	na	48	N18BAB
na	na	48	N18BRB
na	na	40	N19BAB
na	na	130	N19BGBN
na	na	40	N19BPE
na	na	40	N19BRB
na	na	40	N21BAB
na	na	120	N21BGBN
na	na	40	N21BPE
na	na	40	N21BRB
na	na	56	O15BRBB
na	na	56	O16BRBB
na	na	48	O17BRBB
na	na	48	O18BRBB
na	na	48	O19BRBB
na	na	60	P06BAA
na	na	60	P08BABT
na	na	60	P10BAB
na	na	60	P10BPE
na	na	60	P10FAB
na	na	50	P11BAB
na	na	50	P11BPE
na	na	40	P12BAB
na	na	40	P13BAB
na	na	60	P13BGBN
na	na	40	P13BPE
na	na	30	P15BAB
na	na	30	P15BPE

Boxes Per Carton	Cartons Per Pallet	Boxes Per Pallet	Item Code
na	na	30	P17BAB
na	na	40	P19BAB
na	na	40	P21BAB
na	na	64	Q15BAB
na	na	64	Q17BAB
na	na	64	Q17BRB
na	na	64	Q19BAB
na	na	130	Q19BGBN
na	na	64	Q19BRB
na	na	56	Q21BAB
na	na	56	Q21BRB
na	na	48	Q23BAB
na	na	48	Q25BAB
na	na	48	Q25BGBN
na	na	100	Q25BGBN
na	na	48	Q25BRB
12	32	384	R08BAB
12	40	480	R10BAB
12	40	480	R11BAB
12	40	480	R13BAB
10	40	400	W10BAB
12	32	384	W11BABN
na	na	72	X04NRA
na	na2	72	X06NRA
na	na	72	X08NRA
8	32	256	Y05BFA
8	32	256	Y07BFA
8	32	256	Y09BFA

Screws

Boxes Per Carton	Cartons Per Pallet	Boxes Per Pallet	Item Code
6	24	144	O6A125P
na	na	72	O6A125PB*
6	24	144	O6A162P
na	na	72	O6A162PB*
6	24	144	O6A162W
6	24	144	O6B125P
na	na	72	O6B125PB*
6	24	144	O6B162P
6	24	144	O6C100C
6	24	144	O6C125C
na	na	72	O6C125CB*
na	na	72	O6C125PB*
6	24	144	O6C125WK*
6	24	144	O6C162C
na	na	72	O6C162CB*
na	na	72	O6C162PB*
6	24	144	O6C162WK*
6	24	144	O6C200C
na	na	72	O6C200PB*
6	24	144	O7A200P
6	24	144	O7M044PTDPS
na	na	72	O7Q100PB*
6	24	144	O7Q125QS
6	24	144	O7Q125PB*
na	na	72	O7Q125PBQ*
6	24	144	O8A250PK*
na	na	72	O8C125PB
6	24	144	O8C300WK*
6	24	144	O8D175W
6	24	144	O8D200W

Boxes Per Carton	Cartons Per Pallet	Boxes Per Pallet	Item Code
6	24	144	O8D250S
6	24	144	O8D250W
6	24	144	O8D300W
6	24	144	O8F150W
6	24	144	O8F150Y
6	24	144	O8F175Y
6	24	144	O8F200Y
na	na	72	O8F200YBTHSS*
6	24	144	O8F250Y
6	24	144	O8F300Y
6	40	240	O8G100CKNFDP*
6	24	144	O8G150CTLDSS
6	24	144	O8G162CTWFWS*
6	32	192	O8G200CKLFPS*
6	24	144	O8G200CTWFWS
6	24	144	O8G200CTWFWS
6	24	144	O8G250CTWFWS
6	24	144	O8G300CTWFWS
na	na	72	O8L125CBLCTS*
na	na	72	O8L175YB*
6	24	144	O8M050CTRFDP
6	24	144	O8M050CTRFSP
6	24	144	O8R250S
6	24	144	O8R250S596
6	24	144	O8R250W
6	24	144	O8R300W
6	24	144	O8S250W003
6	24	144	O8S250W497
6	24	144	O8S250W592
6	24	144	O8S250W596
6	24	144	O8S300W003
6	24	144	O8S300W497
6	24	144	O8S300W592
6	24	144	O8S300W596
6	24	144	O8T125W
na	na	72	O8T150WBWTDSP*
6	24	144	O8T200W
na	na	72	O8X125CBACTS*
6	40	240	O8X125CKADDS*
6	32	192	O8X200CKADDS*
6	24	144	O9D300S
6	24	144	O10F200Y
1	72	72	O10G125CBWFDS*
6	24	144	O10G162CTWFWS
6	24	144	O10M050CTRFDP
na	na	72	O10M062CBFFAX*
6	40	240	O10M075CKNFDP*
6	24	144	O10M075CTMFDS
6	40	240	O10M075YKFF4X*
na	na	48	O10M075YLF4X
6	24	144	O10M075YTFDFX
6	24	144	O10M100CKMFDS*
6	40	240	O12G175YKLFAX*
6	32	192	O12G200YKLFAX*
6	32	192	O12G250YKLFAX*
6	40	240	O12M087YKFF4X*
6	40	240	O12M100YKFF3X*
6	24	144	O12M150CTFFDX

*Packaged in boxes not tubs

*na indicates not packed in cartons — available in boxes or skids only

THE INNOVATION YOU'VE COME TO EXPECT, NOW WITH 200 PSI

Whether you need a compressor for punch-out jobs or for all-day performance, SENCO offers high quality, reliable options to meet your needs.

FEATURES

Our new line of 200 psi compressors provides plenty of tank storage and air flow for the job site or professional shop. They're equipped with dual couplers so you can run two hoses simultaneously. They feature an oil-free pump design to reduce maintenance, and integrated control panels provide easy access to couplers, control knobs and highly visible gauges. A newly designed full roll cage protects vital components.

These 200 psi options complement SENCO's iconic PC1010N portable finish and trim compressor. Powerful, but also ultra-quiet and lightweight, the PC1010N features an oil-free pump design, integrated control panel, and rugged roll cage.

A full line of hoses and accessories are available for all compressors.



PC0968N

1¼ HP (RUNNING) 4½-GALLON TWIN STACK AIR COMPRESSOR



Features

- 200 max psi
- Heavy-duty induction motor with 95 low volt start
- Rugged roll cage to protect critical components
- Integrated control panel for ease of use

PC0969

1¼ HP (RUNNING) 4½-GALLON ROLL-AWAY AIR COMPRESSOR



Features

- 200 max psi
- Heavy-duty induction motor with 95 low volt start
- Rugged roll cage to protect critical components
- Integrated control panel for ease of use

PC0970

1¼ HP (RUNNING) 15-GALLON VERTICAL ELECTRIC AIR COMPRESSOR



Features

- 200 max psi
- Heavy-duty induction motor with 95 low volt start
- Rugged roll cage to protect critical components
- Integrated control panel for ease of use

200 PSI COMPRESSORS

- More stored energy runs air tools longer
- Fast recovery time increases productivity
- Maintains tool operating pressure longer
- Improves efficiency on the job



Usable Air Per Gallon

Air Compressor Reference Chart

SPECS	PC0968N	PC0969	PC0970
Motor	Induction	Induction	Induction
Amps	14	14	14
Power Source	120 Volts	120 Volts	120 Volts
SCFM @ 90 PSI	4.9	4.9	4.9
Max PSI	200	200	200
Weight	65 lbs (30 kg)	87 lbs (40 kg)	99 lbs (45 kg)
Height	17.75" (451 mm)	27" (686 mm)	40" (1016 mm)
Length	17.25" (438 mm)	18" (457 mm)	18.75" (476 mm)
Width	21" (533 mm)	17" (432 mm)	19.25" (489 mm)
Warranty	1 yr	1 yr	1 yr
FEATURES			
Thermal Overload Protector	Yes	Yes	Yes
Pump	Oil-Free	Oil-Free	Oil-Free
Pump Up/Recovery Time	105 sec./30 sec.	105 sec./30 sec.	345 sec./85 sec.
¼" Quick Connect Coupler	2 (Dual)	2 (Dual)	2 (Dual)
Regulator	Yes	Yes	Yes
Individual Tank and Outlet Gauges	Yes	Yes	Yes
Cold Start Valve	Yes	Yes	Yes
CSA Approved	Yes	Yes	Yes

PC1130

1 HP (RUNNING) 2½-GALLON
FINISH AND TRIM AIR COMPRESSOR



Features

- Cast-iron cylinder for superior pump life
- Light – 39 lbs
- Heavy-duty induction motor

PC0968

1 HP (RUNNING) 2½-GALLON TWIN TANK
FINISH AND TRIM AIR COMPRESSOR



Features

- Compact twin stack tank design
- Light – 38 lbs
- Heavy-duty induction motor

PC1131

2 HP (RUNNING) 4.3-GALLON
TWIN TANK AIR COMPRESSOR



Features

- Cast-iron cylinder for superior pump life
- Compact twin stack tank design
- Heavy-duty induction motor

PC1280

1½ HP (RUNNING) 6-GALLON
FINISH AND TRIM AIR COMPRESSOR



Features

- Compact and balanced pancake tank design
- Light – 38 lbs
- Dual quick connect couplers

Air Compressor Reference Chart

SPECS	PC1130	PC1131	PC0968	PC1280
Motor	Induction	Induction	Induction	Universal
Amps	13	14	8	12
Power Source	115 Volts	115 Volts	115 Volts	115 Volts
SCFM @ 90 PSI	3.5	4.4	2.2	2.8
Max PSI	125	125	135	150
Weight	39 lbs (17.7 kg)	60 lbs (27 kg)	38 lbs (17.24 kg)	38 lbs (17.24 kg)
Height	18.5" (470 mm)	14.5" (368 mm)	13.5" (343 mm)	18" (457 mm)
Length	20.5" (521 mm)	20.5" (521 mm)	16" (406 mm)	17" (432 mm)
Width	8" (203 mm)	16.5" (419 mm)	15" (381 mm)	16.3" (414 mm)
Warranty	1 yr	1 yr	1 yr	1 yr
FEATURES				
Thermal Overload Protector	Yes	Yes	Yes	Yes
Pump	Oil-Lube	Oil-Lube	Oil-Free	Oil-Free
Pump Up/Recovery Time	39 sec./10 sec.	67 sec./16 sec.	82 sec./17 sec.	152 sec./33 sec.
¼" Quick Connect Coupler	1	1	1	2 (Dual)
Regulator	Yes	Yes	Yes	Yes
Individual Tank and Outlet Gauges	Yes	Yes	Yes	Yes
Cold Start Valve	Yes	Yes	No	Yes
CSA Approved	Yes	Yes	Yes	Yes

PC1010

½ HP (RUNNING) 1-GALLON FINISH AND TRIM AIR COMPRESSOR



Features

- Ultra-quiet — 68 dBA
- Ultra-light — 20 lbs
- Heavy-duty induction motor

PC1010N

½ HP (RUNNING) 1-GALLON FINISH AND TRIM AIR COMPRESSOR



Features

- Ultra-quiet — 68 dBA
- Ultra-light — 21 lbs
- Heavy-duty induction motor

PC0947

2" FINISHPRO® 18-BRAD NAILER AND PC1010 COMPRESSOR KIT



18^{GA}

Features

- 1-gallon PC1010 compressor
- 2" 18 gauge brad nailer
- Everything you need to get you started

PC0974

1" MICRO PINNER AND PC1010 COMPRESSOR KIT



23^{GA}

Features

- 1-gallon PC1010 compressor
- 1" 23 gauge micro pinner
- Everything to get you started

Air Compressor Reference Chart

SPECS	PC1010	PC1010N
Motor	Induction	Induction
Amps	4	4
Power Source	115 Volts	115 Volts
SCFM @ 90 PSI	0.7	0.7
Max PSI	125	135
Weight	20 lbs (9.07 kg)	21 lbs (9.53 kg)
Height	13" (330 mm)	12.25" (311 mm)
Length	14" (356 mm)	11.5" (292 mm)
Width	10" (254 mm)	14" (356 mm)
Warranty	1 yr	1 yr
FEATURES		
Thermal Overload Protector	Yes	Yes
Pump	Oil-Free	Oil-Free
Pump Up/Recovery Time	100 sec./31 sec.	125 sec./30sec.
¼" Quick Connect Coupler	1	1
Regulator	Yes	Yes
Individual Tank and Outlet Gauges	Yes	Yes
Cold Start Valve	No	No
CSA Approved	Yes	Yes

Tool Kit Reference Chart

KIT SPECS	PC0947	PC0974
Compressor	PC1010	PC1010
Tool	FinishPro® 18	FinishPro® 10
Trigger	Contact	Sequential
Tool Op. Pressure	70 - 95 psi	70 - 95 psi
Tool Air Inlet	¼" NPT	¼" NPT
Tool Weight	3 lbs (1.6 kg)	2.4 lbs (1.1 kg)
Tool Height	9.3" (238 mm)	6.75" (171 mm)
Tool Length	9.75" (248 mm)	8.9" (225 mm)
Kit Warranty	1 yr	1 yr
Coil Hose	¼" x 25'	¼" x 25'
Air Fittings	Yes	Yes
Tool Oil and Safety Glasses	Yes	Yes
Variety Pack of Fasteners	18 Ga. Brads	23 Ga. Micro Pins
FASTENER SPECS		
Gauge	18 Ga. Brads	23 Ga. Micro Pins
Range	5/8" - 2"	½" - 1"

ACCESSORIES

FILTERS, REGULATORS, LUBRICANTS, PLUGS, COUPLERS, HOSES, PART KITS AND MORE

SENCO offers an assortment of accessories that are precision engineered to meet the demanding requirements of professionals. Be sure that your tool and compressor are running at peak performance by using SENC-certified replacement parts, accessories, hoses, oils and lubricants.



Air Hoses

SENCO offers a wide variety of air hoses in various materials, sizes and specific tions for your job site.

Quick Couple Rubber Hose

SENCO's premium air hoses:

- Handle up to 250 psi working pressure
- 4-to-1 working pressure to burst safety factor
- Oil resistant nitrile tube
- Tough, flexible neoprene cover
- Braided textile reinforcing for max strength and kink resistance
- Remains flexible at temperatures from -40° to 200°F

Description	Hose Size	Length	Qty.	Item #
Gray without fittings (use with LHBtype fittings)	¼"	50 ft.	1	PC0045
Gray without fittings (use with LHB type fittings)	¼"	100 ft.	1	PC0046
Gray without fittings (use with LHB type fittings)	⅜"	50 ft.	1	PC0048
Gray without fittings (use with LHB type fittings)	⅜"	100 ft.	1	PC0049
Gray with MPT ends (use with FPT type fittings)	¼"	50 ft.	1	PC0059
Gray with MPT ends (use with FPT type fittings)	¼"	100 ft.	1	PC0060
Gray with MPT ends (use with FPT type fittings)	⅜"	50 ft.	1	PC0062
Gray with MPT ends (use with FPT type fittings)	⅜"	100 ft.	1	PC0063
Gray with Industrial Interchange Plug & Coupler fittings	¼"	50 ft.	1	PC0064
Gray with Industrial Interchange Plug & Coupler fittings	¼"	100 ft.	1	PC1152
Gray with Industrial Interchange Plug & Coupler fittings	⅜"	50 ft.	1	PC0065
Bulk Gray without fittings (use with LHB type fittings)	¼"	450 ft. & up	1	PC0041
Bulk Gray without fittings (use with LHB type fittings)	⅜"	450 ft. & up	1	PC0042

Bulk hose can only be purchased in reels of 450 feet and up with a maximum of four sections. Priced by the foot. Not packaged for retail.



GRAY WITHOUT FITTINGS
PC0045, PC0046,
PC0048, PC0049



GRAY WITH MPT ENDS
PC0059, PC0060,
PC0062, PC0063



GRAY WITH PLUG
& COUPLER
PC0064, PC1152,
PC0065



BULK GRAY HOSE
PC0041, PC0042

ProFlex™ Reinforced Polyurethane Red Air Hose

Lightest available non-marring flexible hose

- Flexible in weather (-48° to 150°F)
- Durable — oil and fuel resistant
- Working pressure: 250 psi
- MPT-threaded ends

Description	Hose Size	Length	Qty.	Item #
ProFlex™ with MPT ends (use with FPT type fittings)	¼"	50 ft	1	PC0977
ProFlex™ with MPT ends (use with FPT type fittings)	¼"	100 ft	1	PC0978
ProFlex™ with MPT ends (use with FPT type fittings)	⅜"	50 ft	1	PC0979
ProFlex™ with MPT ends (use with FPT type fittings)	⅜"	100 ft	1	PC0980



PROFLEX WITH MPT ENDS
PC0977, PC0978,
PC0979, PC0980

PVC Air Hose

- Specially formulated polyvinyl chloride
- Resistant to lubricating oils, chemicals & ultraviolet sunlight
- Flexible in temperatures -20° to 150°F
- Handles up to 300 psi working pressure
- MPT-threaded ends

Description	Hose Size	Length	Qty.	Item #
PVC with MPT ends (use with FPT type fittings)	¼"	50 ft	1	PC0075
PVC with MPT ends (use with FPT type fittings)	⅜"	50 ft	1	PC0078



PVC WITH MPT ENDS
PC0075, PC0078

Premium Hybrid Polymer Air Hose

- Provides the ultimate in flexibility and memory resistance even in extreme cold temperatures
- Offers the best combination of strength and flexibility on the market

Description	Hose Size	Length	Qty.	Item #
Hybrid with MPT ends (use with FPT type fittings)	¼"	50 ft	1	PC1319
Hybrid with MPT ends (use with FPT type fittings)	¼"	100 ft	1	PC1320
Hybrid Field-Repairable with MPT ends (use with FPT type fittings)	¼"	50 ft	1	PC1321
Hybrid Field-Repairable with MPT ends (use with FPT type fittings)	¼"	100 ft	1	PC1322



HYBRID WITH MPT ENDS
PC1319, PC1320

Plugs & Couplers

Quick connect plugs and couplers are available in the most popular Industrial Interchange styles. Couplers are also available in Universal style.

- Blister-packed for easy display
- Also available bulk-packed in boxes of 10
- Stainless steel locking ball bearings
- Positive alignment and free swiveling action to reduce hose torque
- Packaged hose assembly sets include plug and coupler

Plug-and-coupler hose assembly sets — Industrial Interchange

Description	Body Size	NPT Size	Pack Qty.	Item #
Connects to hose with MPT fittings	¼"	¼" FPT	1	PC0563
Connects to hose without MPT fittings	¼"	¼" LHB	1	PC0565

Universal Couplers — push plug into coupler (no need to pull back on sleeve)

Description	Body Size	NPT Size	Pack Qty.	Item #
Universal Coupler Female	¼"	¼" FPT	1	PC0900
Universal Coupler Female	¼"	¼" FPT	10	PC0698
Universal Coupler Male	¼"	¼" MPT	1	PC0901
Universal Coupler Male	¼"	¼" MPT	10	PC0699

Plugs — Industrial interchange

Description	Body Size	Size	Pack Qty.	Item #
Plug Male	¼"	¼" MPT	2	PC0479
Plug Male	¼"	¼" MPT	10	PC0231
Plug Male	¼"	⅜" MPT	2	PC0480
Plug Male	¼"	⅜" MPT	10	PC0413
Plug Male	⅜"	¼" MPT	2	PC0486
Plug Male	⅜"	⅜" MPT	2	PC0485
Plug Female	¼"	¼" FPT	2	PC0477
Plug Female	¼"	¼" FPT	10	PC0239
Plug Female	¼"	⅜" FPT	2	PC0478
Plug Female	¼"	⅜" FPT	10	PC0410
Plug (push-on barb)	¼"	¼" LHB	1	PC0576
Plug (push-on barb)	¼"	¼" LHB	10	PC0235
Plug (push-on barb)	¼"	⅜" LHB	1	PC0577
Plug (push-on barb)	¼"	⅜" LHB	10	PC0412
Plug (push-on barb)	¼"	¼" SHB	10	PC0243

Couplers — Industrial interchange

Description	Body Size	Size	Pack Qty.	Item #
Coupler Male	¼"	¼" MPT	1	PC0503
Coupler Male	¼"	¼" MPT	10	PC0201
Coupler Male	¼"	⅜" MPT	1	PC0504
Coupler Male	¼"	⅜" MPT	10	PC0380
Coupler Male	⅜"	⅜" MPT	1	PC0509
Coupler Male	⅜"	¼" MPT	1	PC0510
Coupler Female	¼"	¼" FPT	1	PC0501
Coupler Female	¼"	¼" FPT	10	PC0209
Coupler Female	¼"	⅜" FPT	1	PC0502
Coupler Female	¼"	⅜" FPT	10	PC0378
Coupler Female	⅜"	⅜" FPT	1	PC0507
Coupler (push-on barb)	¼"	¼" LHB	1	PC0505
Coupler (push-on barb)	¼"	¼" LHB	10	PC0205
Coupler (push-on barb)	¼"	⅜" LHB	1	PC0506
Coupler (push-on barb)	¼"	⅜" LHB	10	PC0379
Coupler (push-on barb)	¼"	¼" SHB	10	PC0213

(LHB) - Locking Hose Barb, no clamp required when used with SENCO Quick Couple Hose.
(SHB) - Standard Hose Barb, requires hose clamps. See page 75 for hose clamps.



PC0563

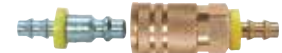

PC0565



COUPLER FEMALE
PC0900, PC0698

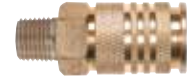

COUPLER MALE
PC0901, PC0699



PLUG MALE
PC0479, PC0231, PC0480,
PC0413, PC0486, PC0485



PLUG FEMALE
PC0477, PC0239,
PC0478, PC0410



PLUG PUSH-ON LOCKING BARB
PC0576, PC0235, PC0577, PC0412



PLUG PUSH-ON STANDARD BARB
PC0243



COUPLER MALE
PC0503, PC0201, PC0504,
PC0380, PC0509, PC0510



COUPLER FEMALE
PC0501, PC0209,
PC0502, PC0378, PC0507



COUPLER PUSH-ON
LOCKING BARB
PC0505, PC0205, PC0506, PC0379



COUPLER PUSH-ON
STANDARD BARB
PC0213

Swivel Plugs & Couplers

- Allow easier access when working in corners and tight spaces
- Reduce fatigue
- Help prevent kinks and reduce stress on hose
- Provide strong and simple connection for pneumatic tools

Swivel Plugs — Industrial interchange

Description	Body Size	NPT Size	Pack Qty.	Item #
Plug Male	¼"	¼" MPT	4	PC1323
Plug Male	¼"	¼" MPT	10	PC1324
Plug Male	¼"	⅜" MPT	4	PC1325



PC1323, PC1324, PC1325

Swivel Couplers — Industrial interchange

Description	Body Size	NPT Size	Pack Qty.	Item #
Coupler Male	¼"	¼" MPT	4	PC1326
Coupler Male	¼"	¼" MPT	10	PC1327
Coupler Female	¼"	¼" FPT	4	PC1328
Coupler Female	¼"	¼" FPT	10	PC1329



PC1328, PC1329

Swivel Couplers — Universal

Description	Body Size	NPT Size	Pack Qty.	Item #
Coupler Female	¼"	¼" FPT	4	PC1330
Coupler Female	¼"	¼" FPT	10	PC1331

Air Hose Accessories

Splicer

Description	Size	Pack Qty.	Item #
Push-On Barbed Hose Splicer	¼" LHB	2	PC0643
Push-On Barbed Hose Splicer	⅜" LHB	2	PC0644



PC0643, PC0644

ProFlex Hose Fittings

Description	Size	Pack Qty.	Item #
Brass Hose End	¼" MPT	1	PC0983
Brass Hose End	⅜" MPT	1	PC0984
Brass Hose End & Splicer	¼" MPT	1	PC0987
Brass Hose End & Splicer	⅜" MPT	1	PC0988



PC0983, PC0984



PC0987, PC0988

Hose Clamps

Description	Size	Pack Qty.	Item #
Hose Clamp	¼"	1	PC0352
Hose Clamp	⅜"	1	PC0353
Hose Clamp	⅝"	1	PC0354
Hose Clamp Crimping Pliers	N/A	1	PC0443



PC0352



PC0353



PC0354



PC0443

Air Hose And Compressor Accessories

Tripod Manifold				
Description	Inlet Thread	Outlet Thread	Pack Qty.	Item #
3-Way Round Manifold	3/8" FPT	1/4" FPT	1	PC0444
3-Way Flat Manifold Industrial Interchange	1/4" Plug	1/4" Coupler	1	PC1138



PC0444



PC1138

Blow Gun			
Description	Inlet Thread	Pack Qty.	Item #
Air Blow Gun	1/4" FPT	1	PC0489



PC0489

Teflon® Thread-Sealing Tape		
Description	Pack Qty.	Item #
1/2" x 260 ft. Sealing Tape	1	PC0349



PC0349

Drain Cock

Drain Cock			
Description	Size	Qty.	Item #
Drains moisture from tank, finger adjustable	1/4" MPT	1	PC0357



DRAIN COCK
PC0357

Filters, Regulators & Gauges

SENCO's assortment of filters, regulators, lubricators and gauges are precision engineered to meet the demanding requirements of professional contractors. Be sure that your compressor is running at peak performance by using SENCO-certified replacement parts and accessories.

Air Regulation Accessories: Regulator with Gauge					
Description	Max psig	Max airflow	FPT size	NPT gauge	Item #
Mini Regulator with Gauge	250	14 SCFM	1/4"	1/8"	PC0656
Regulator with Gauge	300	14 SCFM	1/4"	1/8"	PC0653
Regulator with Gauge	300	80 SCFM	3/8"	1/8"	PC0657
Filter/Regulator with Gauge	150	14 SCFM	1/4"	1/8"	PC0660
Filter	150	14 SCFM	1/4"	—	PC0655
In-Line Regulator (Regulate multiple tools from one compressor)	150	—	1/4"	1/4"	PC0436
Back-Mount Pressure Gauge	160	—	—	1/8"	PC0057
Back-Mount Pressure Gauge	160	—	—	1/4"	PC0051



PC0656



PC0653



PC0657



PC0660



PC0655



PC0436



PC0057



PC0051

Oils & Lubricants

Oils, lubricants, cleaners & coating				
Description	Features	Size	Case Qty.	Item #
Pneumatic Tool Oil (½ pt)	<ul style="list-style-type: none"> Premium-grade oil with high-quality paraffi distillate stock Contains a carefully balanced rust and oxidation inhibitor with an effective anti-foaming additive 	8 oz	12	PC0101
Pneumatic Tool Oil (1 qt)	<ul style="list-style-type: none"> Premium-grade oil with high-quality paraffi distillate stock Contains a carefully balanced rust and oxidation inhibitor with an effective anti-foaming additive 	32 oz	12	PC0102
Pneumatic Tool Oil (1 gal)	<ul style="list-style-type: none"> Premium-grade oil with high-quality paraffi distillate stock Contains a carefully balanced rust and oxidation inhibitor with an effective anti-foaming additive 	128 oz	4	PC0103
Compressor Pump Oil (1 qt)	<ul style="list-style-type: none"> Premium-grade oil with high-quality naphthenic distillate stock Recommended for all oil-splash compressors Protects against corrosion Lubricates to extended part life 	32 oz	12	PC0344
Moisture Shield Tool Lubricant (1 qt)	<ul style="list-style-type: none"> For use in cold weather and/or high moisture areas Protects against corrosion Lubricates to extend part life Special additive to minimize exhaust fog 	32 oz	12	PC1295
Tool Lubricant	<ul style="list-style-type: none"> Protects against corrosion Lubricates to extend part life Special additive to minimize exhaust fog 	4 oz	12	YB0123



PC0101

PC0102

PC0103



PC0344

PC1295

YB0123

Safety Glasses & Tool Belt Hooks

SENCO's safety glasses offer the ultimate in style and comfort while providing the highest level of eye protection, produced with a strong lightweight poly carbonate lens that meet, or exceeds ANSI Z87.1 and CE EN 166 safety standards.

Safety Glasses		
Description	Qty.	Item #
Wrap-around safety glasses*	10-Case	PC1166
Standard clear safety glasses	10-Case	PC1284

*Filters 99% of UVA and UVB rays. For indoor and outdoor use.



PC1166

PC1284

Tool Belt Hooks			
Description	Size	Qty.	Item #
Attaches to ¼" air fitting on tool	Standard	1	PC0350
Attaches to ¼" air fitting on tool	X-Wide	1	PC0629
Attaches to ⅜" air fitting on tool	Standard	1	PC0351
Attaches to ⅜" air fitting on tool	X-Wide	1	PC0630
Attaches to belt and fits FinishPro42XP	Standard	1	PC0934



BELT HOOK
PC0350

BELT HOOK
PC0629



BELT HOOK
PC0351

BELT HOOK
PC0630

BELT HOOK
PC0934

Battery Systems

Compatible with all 18V Li-Ion Duraspin II and SENCO FUSION tools

18V Li-Ion Battery 1.5 amp hour	Fits	
VB0155	DS212-18V DS215-18V DS312-18V F-15 F-16A F-16S F-18	
		<ul style="list-style-type: none"> • 1.5 amp hours • High-quality reliable cells • Longer storage life • Charges 80% in 15 minutes
18V Li-Ion Battery 3.0 amp hour	Fits	
VB0161	DS212-18V DS215-18V DS312-18V F-15 F-16A F-16S F-18	
		<ul style="list-style-type: none"> • 3.0 amp hours • High-quality reliable cells • Longer storage life • Drives up to 2X as many fasteners as VB0155

Charger System

Can be used interchangeably with SENCO VB0155, VB0161, and VB0118 batteries

Battery Charger	For use with	
VB0156	VB0155 VB0161 VB0118	
		<ul style="list-style-type: none"> • Battery charge indicators display charge status of your battery • Compatible with all SENCO 18V Li-Ion batteries.

No-Mar Pads

NO-MAR pads replacement, one per pack



No-Mar Pads Fit	Item #
AF25, CF25	HF0083
AF41, CF41	HF0079
FIP11	HF0463
FIP15, FIP18	HF0506
FIP15Mg, FIP18Mg	HF0571
FIP23SXP, 23LXP, 21LXP	HC0729
FIP25XP	HF0064
FIP32*	HF0396
FIP32**	HF0401
FIP41XP, FIP42XP	HF0079
FN55AX	HF0113
FN65DA	HF0110
FP600-650 SERIES	HF0046, HC0253
FP601, FP602, FP651, FP652*	HA0170
FP700 SERIES	HF0046, HC0253

No-Mar Pads Fit	Item #
GT65DA	HC0626
GT65RHA	HC0625
GT90CH	HA0200
GT90FRH	HA0201
SCN49	HC0536
SCN56	070063
SFN30, SFN40, SFN1	HF0079
SFN2	HB0057
SLS15, SLS18	HC0507
SLS15Mg, SLS18Mg	HC0572
SLS20, SLS20XP (K, L & R CROWNS)	HF0028
SLS20, SLS20XP (M CROWN)	HF0029
SLS25-L, SLS25XP-L	HF0028

PARTS KITS

Maintaining Your Tools

SENCO repair kits are designed to provide the parts normally needed to properly maintain and service your SENCO tools.



Tool Model	Description	Item Code
FinishPro 15, 18, 2N1	Repair Kit	YK0393
FinishPro 15Mg, 18Mg	Repair Kit	YK0780
FinishPro 23LXP, 21LXP	Repair Kit	YK0855
FinishPro 23SXP	Repair Kit	YK0854
FinishPro 25XP	Firing System Kit	YK0281
FinishPro 25XP	Piston Stop Kit	YK0282
FinishPro 32	Repair Kit	YK0394
FinishPro 33MG	Repair Kit	YK0787
FinishPro 35	Repair Kit	YK0365
FinishPro 41XP, 42XP	Firing System Kit	YK0361
FinishPro 41XP, 42XP	Piston Stop Kit	YK0362
FramePro 601, 602, 651, 652	Repair Kit	YK0360
FramePro XP 701, 752, 702, 752	Firing System Kit	YK0243
FramePro XP 701, 752, 702, 752	Piston Stop Kit	YK0244
HN150, HN250	Repair Kit	BA0158
JoistPro150XP	Repair Kits	YK0823 YK0824
JoistPro250XP	Repair Kits	YK0825 YK0826
LS1XP	Repair Kit	YK0858
MW	Repair Kit	YK0371
PAL57F	Repair Kit	YK0446
PAL70	Repair Kit	YK0447
PAL90	Repair Kit	YK0774
PAL100	Repair Kit	YK0777
PW150, PW200	Repair Kit	YK0402
PW150R	Repair Kit	YK0403
RoofPro™ 455XP	Firing System Kit	YK0424
RoofPro™ 445XP	Repair Kit	YK0865
RoofPro™ 455XP	Piston Stop Kit	YK0426
RoofPro™ 450XP	Repair Kit	YK0426
SC 1	Repair Kit	YK0370
SC 2	Repair Kit	YK0371
SCN48	Repair Kit	YK0769
SCN49	Repair Kit	YK0771
SCN60, SCN65	Repair Kit	YK0366
SFN1, SKS, SPS	Repair Kit	YK0376
SFN1, SKS, SPS	Retrofit Kit	YJ0035
SFN30	Repair Kit	YK0368
SFN40	Repair Kit	YK0367

Tool Model	Description	Item Code
SFT 10XP, SFT 10XP D/L, SFT 10XP LN	Piston Stop Kit	YK0802
SFT 10XP, SFT 10XP D/L, SFT 10XP LN	Firing System Kit	YK0803
SFT 10XP (AUTO)	Firing System Kit	YK0802
SFT 10XP (AUTO D/L)	Firing System Kit	YK0804
SFT 10XP (AUTO D/L)	Piston Stop Kit	YK0802
SFN1, SKS, SPS	Kit Firing System Kit	YK0804
SFW09	Repair Kit	YK0775
SFW10XP	Piston Stop Kit	YK0321
SFW10XP	Firing System Kit	YK0322
SLP20	Repair Kit	YK0373
SLS15, SLS18	Repair Kit	YK0393
SL15MG, SLS18MG	Repair Kit	YK0780
SLS20	Repair Kit	YK0372
SLS25XP	Piston Stop Kit	YK0291
SLS25XP	Firing System Kit	YK0359
SCP40XP	Firing System Kit	YK0444
SCP40XP	Piston Stop Kit	YK0445
SN901XP, SN902XP, FramePro325XP	Firing System Kit	YK0444
SN901XP, SN902XP, FramePro325XP	Piston Stop Kit	YK0445
SN951XP, SN952XP	Firing System Kit	YK0444
SN951XP, SN952XP	Piston Stop Kit	YK0768
SNS40	Repair Kit	YK0374
SNS41	Repair Kit	YK0423
SNS41 (Retrofit Kit)	Cap/Firing valve	YJ0034
SNS44XP	Firing System Kit	YK0421
SNS44XP	Piston Stop Kit	YK0422
SNS45XP	Firing System Kit	YK0230
SNS45XP	Piston Stop Kit	YK0231
SNS50XP, SQS55XP	Repair Kit	YK0375
SNS200XP-BST	Firing System Kit	YK0838
SNS200XP-BST	Piston Kit	YK0839
SNS200XP	Firing System Kit	YK0840
SNS200XP	Piston Kit	YK0841
SNS200XP	Block-Out Kit	YK0850
SNS200XP	Siding Safety Kit	HC0748
WC150RXP, WC150XP, WC200XP	Repair Kit	YK0783
WC150RXP, WC150XP, WC200XP	Block-Out Kit	YK0786
WC150RXP, WC150XP, WC200XP	Retrofit Kit-Solid Safety	YJ0037

See tool parts chart for complete list of available individual parts. Download SENCO tool parts chart at www.senco.com

FINISH & WOODWORKING

FinishPro23SXP 8F0001N	FinishPro23LXP 8L0001N	FinishPro21LXP 8M0001N	FinishPro18Mg 1U0021N	SLP20XP 430101N	FinishPro25XP 760102N
					
Pg. 19	Pg. 19	Pg. 19	Pg. 20	Pg. 20	Pg. 20
FinishPro32 1X0201N	FinishPro33Mg 6F0001N	SFN30 620002N	FinishPro35Mg 6G0001N	FinishPro42XP 4G0001N	SLS20XP SEE SPECIFICATIONS
					
Pg. 20	Pg. 21	Pg. 21	Pg. 21	Pg. 21	Pg. 22
SLS25XP SEE SPECIFICATIONS	SKSXP SEE SPECIFICATIONS	SLS150Mg 8C0001N	SLS18Mg 1W0021N	SC1XP 220101N	SC2 470001N
					
Pg. 22	Pg. 22	Pg. 23	Pg. 23	Pg. 23	Pg. 23

Fasteners: see pages 24 - 29

FRAMING, SHEATHING & SUBFLOORS

FramePro325XP 4Z0101N	FramePro701XP 2H0133N	SN951XP 5B0001N	FramePro325FRHXP 4H0101N	FramePro702XP 2K0103N	FramePro752XP 2F0103N	
						
Pg. 31	Pg. 31	Pg. 31	Pg. 32	Pg. 32	Pg. 32	
SN952XP 5A0001N	SCN60XP 520101N	SCN65XP 540101N	SCN63LDXP 8W0001N	JoistPro150XP 7L0001N	JoistPro250XP 6K0001N	Mini Hand Nailer PC1195
						
Pg. 32	Pg. 33	Pg. 33	Pg. 33	Pg. 34	Pg. 34	Pg. 34
A20 Hand Nailer PC0781	SCP40XP 7J0001N	WC150XP 4W0001N	WC200XP 4Y0001N	SNS41 3L0003N	SNS200XP 7B0001N	SQS55XP 660101N
						
Pg. 34	Pg. 35	Pg. 35	Pg. 35	Pg. 36	Pg. 36	Pg. 36

Fasteners: see pages 37 - 45

ROOFING & SIDING

RoofPro455XP	RoofPro445XP	SCN49XP	WC150RXP	BC58 Button Cap	A11 Stapling Hammer
3D0101N	8V0001N	5J0001N	4X0001N	4A0001N	PC0700
					
Pg. 47	Pg. 47	Pg. 33 & 47	Pg. 48	Pg. 48	Pg. 48

Fasteners: see pages 49 - 51





FLOORING

SHF200	SHFS200	SLS20XP-HF
8D0001N	8D0002N	490021N
		
Pg. 65	Pg. 65	Pg. 65

Fasteners: see page 66



PALLETS & CRATING

PalletPro57XP	PalletPro100XP	PalletPro130XP	DFPXP	F75LXP	F75SXP
4L0001N	5L0001N	5M0001N	8H0001N	8J0002N	8J0001N
					
Pg. 53	Pg. 53	Pg. 53	Pg. 54	Pg. 54	Pg. 54

Fasteners: see pages 55 - 57

UPHOLSTERY & FURNITURE

SFT10XP, Long Nose, and Double-Length Magazine	SFW09	SNS200XP-BST
SEE SPECIFICATIONS	4C0001N	7C0001N
		
Pg. 59	Pg. 60	Pg. 60

Fasteners: see pages 61 - 63



COMPRESSORS

PC0968N	PC0969	PC0970	PC1130	PC1131	PC0968	PC1280	PC1010	PC1010N
								
Pg. 71	Pg. 71	Pg. 71	Pg. 72	Pg. 72	Pg. 72	Pg. 72	Pg. 73	Pg. 73



SCREW SYSTEMS

DS215-18V 7W0001N	DS212-18V 7X0001N	DS312-18V 7Y0001N	DS235-AC 7T0001N	DS232-AC 7U0001N	DS332-AC 7V0001N
					
Pg. 3	Pg. 3	Pg. 3	Pg. 4	Pg. 4	Pg. 4
DS425AC 6W0012N		DS440AC 6W0011N		DS220 6W0001N	
					
Pg. 5		Pg. 5		Pg. 6	
DS320 6W0003N				SG4100 6X0004N	SG2510 6X0002N
					
Pg. 6				Pg. 7	Pg. 7

Fasteners: see pages 8 - 11

DURASPIN[®]
TECHNOLOGY

FUSION

F-18 6E0001N	F-16S 6U0001N	F-16A 5P0001N	F-15 5N0001N
			
Pg. 15	Pg. 15	Pg. 15	Pg. 15

Fasteners: see pages 16 - 17

FUSION[™]
TECHNOLOGY

LI-ION BATTERIES & CHARGERS

18V LI-ION VB0155	18V 3AH VB0161
	
Pg. 13, 15 & 80	Pg. 13, 15 & 80
18V LI-ION CHARGER VB0156	
	
Pg. 13, 15 & 80	



Item Code Index

Item code	Description	Pg
1U002IN	FinishPro18Mg 18 Ga. Brad Nailer	20
1W002IN	SLS18Mg 18 Ga. (L wire ¼" crown)	23
1X020IN	FinishPro32 16 Ga. Finish Nailer	20
2F0103N	FramePro752XP FRH 20° Framing Nailer	32
2H0133N	FramePro701XP Framing Nailer (30°-34°)	31
2K0103N	FramePro702XP FRH 20° Framing Nailer	32
22010IN	SC1XP	23
3D010IN	RoofPro455XP Roofing Coil Nailer	47
3L0003N	SNS41 17-16 Ga. (O/N wire 7/16" crown)	36
300120N	SKSXP-L 18 Ga. (L wire ¼" crown)	22
300152N	SKSXP-M 18 Ga. (M wire 3/8" crown)	22
300184N	SKSXP-N 16 Ga. (N wire 7/16" crown)	22
4A0001N	BC58 Button Cap Stapler, w/case	48
4C0001N	SFW09 22 Ga. (C wire 3/8" crown)	60
4G0001N	FinishPro42XP 15 Ga. Finish Nailer	21
4H010IN	FramePro325FRHXP	32
4L0001N	PalletPro57FXP Coil Nailer	53
4W0001N	WC150XP 16 Ga. (P wire 1" crown)	35
4X0001N	WC150RXP Roofing 16 Ga. (P wire 1" crown)	48
4Y0001N	WC200XP Lathing 16 Ga. (P wire 1" crown)	35
4Z010IN	FramePro325XP Framing Nailer (30°-34°)	31
43010IN	SLP20XP 18 Ga. Brad Nailer	20
470001N	SC2 Corrugated Fastener Tool	23
490009N	SLS20XP-M 18 Ga. (M wire 3/8" crown)	22
490015N	SLS20XP-L 18 Ga. (L wire ¼" crown)	22
490021N	SLS20XP-HF Hardwood Flooring 19 Ga. (R wire 3/16" crown)	22
49010IN	SLS20XP-K 19 Ga. (K wire ¼" crown)	22
490103N	SLS20XP-L 18 Ga. (L wire ¼" crown)	22
490105N	SLS20XP-L 18 Ga. (L wire ¼" crown)	22
490107N	SLS20XP-M 18 Ga. (M wire 3/8" crown)	22
490111N	SLS20XP-R 19 Ga. (R wire 3/16" crown) SN952XP	22
5A0001N	Framing Nailer (full round head) SN951XP	32
5B0001N	Framing Nailer (30°-34°)	31
5J0001N	SCN49XP Siding Coil Nailer	47
5L0001N	PalletPro100XP Coil Nailer	53
5M0001N	PalletPro130XP Coil Nailer	53
5N0001N	FUSION F-15 Battery 15 Ga. 34° Finish Nailer	15
5P0001N	FUSION F-16A Battery 16 Ga. 20° Finish Nailer	15
52010IN	SCN60XP Coil Nailer	33
54010IN	SCN65XP Coil Nailer	33
540104N	SCN65XP Coil Nailer, Toenail Safety	33
6E0001N	FUSION F-18 Battery 18 Ga. Brad Nailer	15
GF0001N	FinishPro33Mg 16 Ga. 20° Finish Nailer	21
6G0001N	FinishPro35Mg 15 Ga. 34° Finish Nailer	21
6K0001N	JoistPro250XP Metal Connector Nailer	34
6S0001N	SFT10XP-A/D 22 Ga. (A/D wire 3/16" crown)	59
6S010IN	SFT10XP-A/D Auto 22 Ga. (A/D wire 3/16" crown)	59
6S001IN	SFT10XP-B 22 Ga. (B wire ½" crown)	59
6S021IN	SFT10XP-B D/L 22 Ga. (B wire ½" crown)	59
6S031IN	SFT10XP-B Auto D/L 22 Ga. (B wire ½" crown)	59

Item code	Description	Pg
6S002IN	SFT10XP-C 22 Ga. (C wire 3/8" crown)	59
6S012IN	SFT10XP-C Auto 22 Ga. (C wire 3/8" crown)	59
6S022IN	SFT10XP-C D/L 22 Ga. (C wire 3/8" crown)	59
6S032IN	SFT10XP-C Auto D/L 22 Ga. (C wire 3/8" crown)	59
6S042IN	SFT10XP-C Long Nose 22 Ga. (C wire 3/8" crown)	59
6S003IN	SFT10XP-E 20 Ga. (E wire 3/8" crown)	59
6S004IN	SFT10XP-F 20 Ga. (F wire ½" crown)	59
6S034IN	SFT10XP-F Auto D/L 20 Ga. (F wire ½" crown)	59
6S005IN	SFT10XP-G 20 Ga. (G wire 3/8" crown)	59
6S025IN	SFT10XP-G D/L 20 Ga. (G wire 3/8" crown)	59
6S035IN	SFT10XP-G Auto D/L 20 Ga. (G wire 3/8" crown)	59
6S036IN	SFT10XP-H Auto D/L 20 Ga. (H wire 7/16" crown)	59
6U0001N	FUSION F-16S Battery 16 ga. Finish Nailer	15
6X0002N	SG2510 2500 RPM Screwdriver	7
6X0004N	SG4100 4000 RPM Screwdriver	7
6W0001N	DS220 Auto-Feed Screwdriver Attachment	6
6W0003N	DS320 Auto-Feed Screwdriver Attachment	6
6W0011N	DS440AC Auto-Feed Screwdriver Attachment Kit	5
6W0012N	DS425AC Auto-Feed Screwdriver Attachment Kit	5
620002N	SFN30 15 Ga. Finish Nailer	21
66010IN	SQS55XP 15 Ga. (Q wire 7/16" crown)	36
7B0001N	SNS200XP 16-17 Ga. (O/N wire 7/16" crown)	36
7C0001N	SNS200XP-BST, 16 - 17 Ga. (O/N wire 7/16" crown)	60
7J0001N	SCP40XP Pneumatic Concrete and Steel Pinner	33
7L0001N	JoistPro150XP Joist Hanger Nailer	34
7T0001N	DS235-AC Auto-Feed Screwdriver	4
7U0001N	DS232-AC Auto-Feed Screwdriver	4
7V0001N	DS332-AC Auto-Feed Screwdriver	4
7W0001N	DS215-18v Auto-Feed Screwdriver	3
7X0001N	DS212-18v Auto-Feed Screwdriver	3
7Y0001N	DS312-18v Auto-Feed Screwdriver	3
760102N	FinishPro25XP 18 Ga. Brad Nailer	20
8C0001N	SLS150Mg-L 18 Ga. (L wire ¼" crown)	23
8D0001N	SHF200 Hardwood Flooring Nailer	65
8D0002N	SHFS200 Hardwood Flooring Stapler	65
8F0001N	FinishPro23SXP 23 Ga. Headless Pinner	19
8H0001N	DFPXP Staples Clinch Tool 20 Ga. (F wire ½" crown)	54
8J0001N	F75SXP Staples Sisal Anvil Tool 18 Ga. (J wire 7/16" crown)	54
8J0002N	F75LXP Staples Clinch Tool 18 Ga. (J wire 7/16" crown)	54
8L0001N	FinishPro23LXP 23 Ga. Headless Pinner	19
8M0001N	FinishPro21LXP 21 Ga. Medium Head Pinner	19
8W0001N	SCN63LDXP (Long drive coil nailer)	33
8V0001N	RoofPro445XP Coil Roofing Nailer	47
820103N	SLS25XP-L 18 Ga. (L wire ¼" crown)	22
820107N	SLS25XP-M 18 Ga. (M wire 3/8" crown)	22
MA0013	Vinyl Siding Attachment for RoofPro455XP	49
HA0308	Vinyl Siding Attachment for RoofPro445XP	49
PC0700	A11 Stapling Hammer 20 Ga. (H wire 7/16" crown)	48

SENCO®



Looking for more?

Contact Us

4270 Ivy Pointe Blvd.
Cincinnati, OH 45245

Phone: 800.543.4596
Fax: 800.543.3299



Visit Us

on the web for more information
SENCO.com



Find Us

Search for your closest Senco dealer
SENCO.com/dealer-locator



Watch Us

Check out all of our latest videos and product launches
 Youtube.com/SencoBrands



Follow Us

on Twitter and Facebook for the latest Senco news
  [@SencoBrands](https://twitter.com/SencoBrands)

